



Transport for NSW

# Heavy Vehicle Driver Handbook





# Heavy Vehicle Driver Handbook

The Heavy Vehicle Driver Handbook covers the main road rules and requirements for driving heavy vehicles on NSW roads. This handbook also aims to help you get your heavy vehicle licence and to drive safely.

It is written in plain, easy to understand language and should not be taken as a precise interpretation of the law.

To see the complete set of laws for heavy vehicles and drivers visit:

- Road Rules at **[legislation.nsw.gov.au](http://legislation.nsw.gov.au)**
- Heavy Vehicle National Law and Regulations at **[nhvr.gov.au](http://nhvr.gov.au)**

This handbook is reviewed and updated periodically. Check our website at **[nsw.gov.au](http://nsw.gov.au)** for the latest information.

## Other important publications for heavy vehicle drivers:

---

- Road User Handbook
- A Guide to the Driving Test
- Load Restraint Guide
- A Guide to Heavy Vehicle Competency Based Assessment (issued after passing a heavy vehicle driver knowledge test)
- Heavy Vehicle Competency Based Assessment Learner Log book (issued after passing a heavy vehicle driver knowledge test)

# Introduction

The Heavy Vehicle Driver Handbook will help you understand what you need to know about driving a heavy vehicle. It is a useful guide outlining the special rules and regulations, skills and correct attitude needed by professional drivers. This publication must be read along with the Road User Handbook and Load Restraint Guide to prepare for the heavy vehicle driver knowledge test.

# Contents

<b>How to use this handbook</b>	<b>7</b>
<hr/>	
<b>Licences</b>	<b>9</b>
<hr/>	
Getting your heavy vehicle licence	9
Bribing people is against the law	9
Medical assessment	10
Licence classes	11
Upgrading from a P2 licence	17
Learning to drive	18
Heavy Vehicle Competency Based Assessment (HVCBA)	18
Knowledge test	19
Driving Test	19
National Heavy Vehicle Driver Licence	21
<b>Driver management</b>	<b>22</b>
<hr/>	
Health of professional drivers	22
Driver fatigue	23
Causes of fatigue	23
Signs of driver fatigue	24
Tips to manage driver fatigue	24
Roadside rest areas	25
National Heavy Vehicle (Fatigue Management)	25
Driver fatigue and workplace health safety	26
Chain of responsibility	27
Work and rest options	28
National driver work diary	35
Completing your work diary	35
Looking after your work diary	36
Driver base	36
Alcohol, drugs and professional drivers	37
Alcohol and driving	37
Getting back to zero	37
What does not sober you up	37
Drugs and driving	38
Drug testing	40
Seatbelts	41
Entering and exiting a vehicle	42

## **Safe driving 43**

---

Low risk driving	43
Observation	43
Speed management	43
Road positioning	43
Crash avoidance space	43
Vehicle controls	46
Basic driving techniques	51
Hills	51
Before entering a sharp curve	52
Slowing and stopping	52
Animals and vehicles	53

## **Heavy vehicle road rules 54**

---

Speed limits	54
Driving in wet conditions	56
Intersections	56
Reversing	58
Overtaking	58
Lane changing	59
Restricted areas for road trains and B-doubles	59
Height and length limits	60
Light traffic roads	61
Load limit sign	61
No truck sign	61
Trucks must enter sign	61
Where heavy vehicles can stand or park	61
Warning triangles	62
Truck and bus lanes	62
Buses	63
Fires	64
Vehicle monitors	65

## **Knowing the vehicle 68**

---

Roadworthiness	68
Body/cab condition	68
Brakes	68
Couplings	73
Driving controls	73
Electrical system	73
Engine	73

Exhaust system	73
Fuel system	73
Gear boxes	74
Lights and indicators	75
Rear marking plates	76
Rust and corrosion	77
Seats and seatbelts	78
Steering	78
Structure	78
Suspension	78
Wheels and tyres	78
Windscreen and windows	78
Pre-departure checks	79
Pre-departure safety checks	79
Dealing with problems	81
Defect reporting	81
Uncoupling and coupling	82
Uncoupling a semi-trailer	82
Coupling a semi-trailer	84
Uncoupling a truck and trailer	86
Coupling a truck and trailer	87
<b>Vehicle dimensions and loading</b>	<b>88</b>
Load shift	88
Vehicle dimensions	88
The right vehicle	89
Contained loads	90
Heavy loads	90
High loads	91
Tankers	91
Loading	93
Projecting loads	94
Dangerous projections	95
Load distribution and arrangement	96
Positioning the load	97
Securing the load	97
Load restraints	98
Blocking	99
Stakes in pockets	100
Crowned loads	100
Divided crowned loads	101

Dunnage	101
Gates/Fencing	102
Containers	102
Lashings	103
Belly wrapping	104
Large pipe loads	104
Load anchorage points	105
Friction	105
Sheets and tarpaulins	105
Dangerous goods	106
The correct licence	106
Risks	107
Heavy vehicle road access permits and notices	110
<b>Penalties</b>	<b>111</b>
<hr/>	
Traffic offences	111
Demerit points	111
Good behaviour period	112
Speeding offences	112
Speed limiter offences	112
Refusal of a licence	113
Safe-T-Cam	113
Heavy vehicle safety stations	113
Truckalyser	114
Alcohol and drug offences	114
Noise pollution	114
Smoke from engines	118
Defect notices	119
Formal warning	119
Minor defect	119
Major defect	120
Major defect – grounded	120
Transport for NSW inspectors	121
Compliance and Enforcement	122
<b>Industry glossary</b>	<b>124</b>
<hr/>	
<b>Index</b>	<b>129</b>
<hr/>	
<b>Useful contacts</b>	<b>132</b>
<hr/>	



# How to use this handbook

The Heavy Vehicle Driver Handbook is an informative resource addressing the rules and regulations that apply to heavy vehicles and the obligations of heavy vehicle drivers. This publication must be read in conjunction with the Road User Handbook and Load Restraint Guide before undertaking a heavy vehicle driver knowledge test.

This handbook is divided into sections to make it easy to find what you need to know to operate a heavy vehicle safely on the road. At the end of each section is a summary of the information.

You will need to refer to this handbook - in conjunction with the Road User Handbook - if you are taking the Driving Test to get your heavy vehicle driver licence, or by doing a Heavy Vehicle Competency Based Assessment (HVCBA). It is also helpful for experienced drivers who want to check current rules and practice. To find information on a specific topic, go to the Index at the back of the handbook where subjects are listed with page numbers. You will also find a glossary of terms in the back to explain the meaning of words used in the heavy vehicle industry.

## Section 2 - Licences

The licensing system for drivers of heavy vehicles including the skills and qualifications you need to drive a particular vehicle.

## Section 3 - Driver management

The need for professional drivers to be aware of their fitness, and their responsibilities, in particular the laws on alcohol, drugs, fatigue, record-keeping and seatbelts.

## Section 4 - Safe driving

Important low risk driving behaviours such as observation, speed management, road positioning and crash avoidance space.

## Section 5 - Heavy vehicle road rules

A detailed coverage of the road rules that govern heavy vehicles and road users including the regulations on vehicle monitors.

## Section 6 - Knowing the vehicle

The requirements for keeping your vehicle roadworthy covering most vehicle components and functions such as checking, testing, maintenance and inspections. This section includes user friendly checklists.

### CHECKLIST ICON

Checklists are provided to guide you through procedures and general checks. This icon will help you locate them.

## Section 7 - Vehicle dimensions and loading

The dimensions of vehicles and allowable loads; ways to secure and distribute loads, types of loads such as dangerous goods and vehicle types including B-doubles and road trains.

## Section 8 - Penalties

Penalties for traffic offences and offences directly related to driving heavy vehicles.

# Licences

As a professional driver with a heavy vehicle licence, you have a responsibly to keep the roads safe for everyone.

To hold a heavy vehicle driver licence you must meet certain conditions and rules that apply only to drivers of heavy vehicles. This handbook contains information, skills and knowledge needed to get a heavy vehicle driver licence.

## Getting your heavy vehicle driver licence

---

There are two pathways to get your heavy vehicle licence. These depend on where you live and what heavy vehicle licence class you need.

1. **Heavy Vehicle Competency Based Assessment (HVCBA)** – the main way to get a heavy vehicle licence. HVCBA is completed with a Registered Training Organisation (RTO).
2. **Heavy Vehicle Driving Test** – in areas where the HVCBA is not available, you can do a Heavy Vehicle Driving Test.

Transport for NSW accredit RTOs with heavy vehicle licensed driving instructors to conduct HVCBA. The Driving Test is conducted by Service NSW testing officers.

## Bribing people is against the law

---

It is illegal to offer, request or accept gifts, rewards, money or other favours to get a licence without passing the required tests. Penalties are severe and include fines and imprisonment. All cases of corruption will be reported and investigated, and strong action will be taken against all those involved.

If you know or believe that someone has got or is about to get a NSW licence by offering or responding to a request for a bribe – or if you suspect or know of any other corruption involving a NSW Government employee – call Transport for NSW on **1800 302 750** (free call) or the Independent Commission Against Corruption (ICAC) on **(02) 8281 5999**. This includes Transport for NSW accredited RTOs and their driving assessors.

## Medical assessment

---

When you apply for or renew your heavy vehicle licence, you must complete a form with questions about your fitness to drive a heavy vehicle safely. On the basis of this information you may need to visit your doctor to complete a medical online.

NSW adopts the national medical standards for private and commercial drivers contained in the Assessing Fitness to Drive, Commercial and Private Vehicle Drivers booklet, published by Austroads and approved by the Australian Transport Council. These standards apply to those licence holders of class MR and higher who are required to provide a medical report.

### Proof of identity and NSW residential address

You need to provide proof of your identity and NSW residential address to apply for a heavy vehicle driver licence. If your name has changed you may need other documents for the changes.

## Licence classes

The following diagram shows heavy vehicle driver licence classes.

You may drive any class of vehicle appearing below your licence category on the diagram.

At the highest level is an MC licence which allows you to drive all types of vehicles except motorcycles.

### Heavy vehicle licence classes

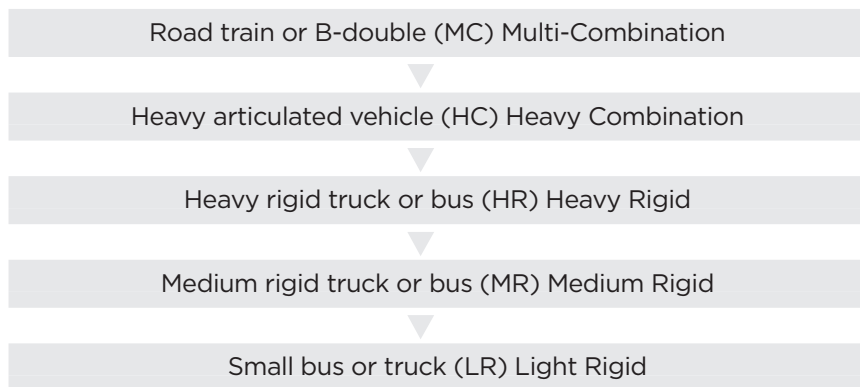

## LR (Light rigid licence)

---

### THE VEHICLE YOU WANT TO DRIVE

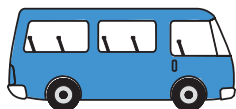

#### RIGID

---

Yes

#### NUMBER OF PASSENGERS INCLUDING THE DRIVER

---

More than 12 adults including the driver.

#### GVM

---

GVM not greater than 8T.

Any towed trailer must not weigh greater than 9T GVM.

### What you need to get this licence

- Have held a class C licence, (except a learner licence) or equivalent for one year or more.
- Pass a knowledge test.
- Pass an eyesight test.
- Pass either a Driving Test or a HVCBA.

A person who holds a provisional P1 licence is not eligible for an LR licence.

## MR (Medium rigid licence)

### THE VEHICLE YOU WANT TO DRIVE

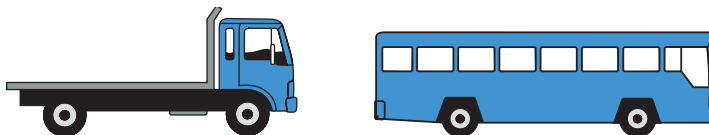

#### RIGID

Yes

#### NUMBER OF AXLES

2

#### GVM

GVM greater than 8T.

Any towed trailer must not weigh greater than 9T GVM.

### What you need to get this licence

- Have held a class C licence, (except a learner licence) or equivalent for one year or more.
- Pass a knowledge test.
- Pass an eyesight test.
- Pass either a Driving Test or a HVCBA.

A person who holds a provisional P1 licence is not eligible for an MR licence.

## HR (Heavy rigid licence)

THE VEHICLE YOU WANT TO DRIVE (note the number of axles)

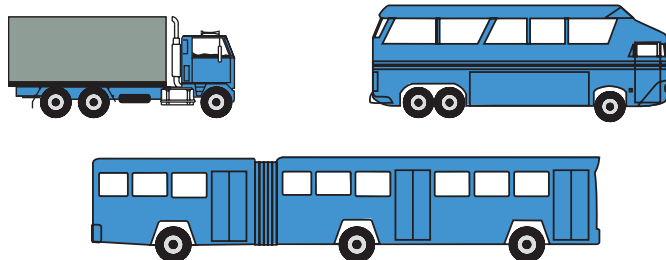

### RIGID

Yes

Note: Bendi-buses are treated as rigid vehicles.

### NUMBER OF AXLES

3 or more

### GVM

GVM greater than 8T.

Any towed trailer must not weigh greater than 9T GVM.

## What you need to get this licence

- Have held a class C licence, (except a learner licence) or equivalent for two years or more.
- Pass a knowledge test.
- Pass an eyesight test.
- Pass either a Driving Test or a HVCBA.

The minimum test vehicle for a HR Driving Test or HVCBA is a three axle rigid vehicle with a GVM of more than 15 tonnes - excluding bobtail prime mover.

A person who holds a provisional P1 licence is not eligible for a HR licence.



## HC (Heavy combination licence)

THE VEHICLE YOU WANT TO DRIVE (note the number of axles)



**ARTICULATED VEHICLE OR  
HEAVY RIGID VEHICLE TRAILER COMBINATION INCLUDING  
UNLADEN DOLLY**

Yes

**NUMBER OF AXLES**

3 or more

**GVM**

Any towed trailer with GVM of more than 9T.

### What you need to get this licence

- Have held a class MR or HR licence or equivalent for one year or more.
- Pass a knowledge test.
- Pass an eyesight test.
- Pass either a Driving Test or a HVCBA.

The minimum test vehicle for a HC Driving Test or HVCBA is a three axle prime mover with a minimum two axle semi-trailer or a heavy rigid vehicle plus trailer over nine tonnes GVM.

A person who holds a provisional P2 licence is not eligible for a HC licence.

## MC (Multi-combination licence)

---

### THE VEHICLE YOU WANT TO DRIVE

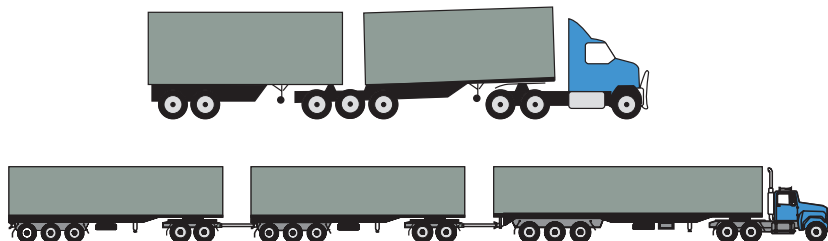

### ROAD TRAIN OR B-DOUBLE

---

Yes

### What you need to get this licence

- Have held a class HR or HC licence or equivalent for one year or more.
- Pass a knowledge test.
- Pass an eyesight test.
- Pass a HVCBA. Applicants holding a class HR licence are required to pass a class HC licence assessment before attempting MC training.
- Pass a medical examination.

### Medical examinations

For licence class MC, a medical is required:

- to first obtain an MC licence
- at age 21 then every 10 years
- at age 40 then every five years
- at age 60 then every two years
- at age 70 then annually.

A person who holds a provisional P2 licence is not eligible for an MC licence.

## Upgrading from a P2 licence

---

Provisional P2 licence holders (who also hold a Class LR, MR or HR heavy vehicle licence) will remain on a provisional licence until they have held the P2 licence for a minimum of two years or if the P2 driver has been suspended for unsafe driving behaviour becomes eligible for the upgrade. There is no variation to this rule and an unrestricted licence will not be issued until the applicant complies with the requirements of the Graduated Licensing Scheme.

## Learning to drive

You can learn to drive heavy vehicles on your current licence if you are eligible to apply for the particular vehicle type.

You must be accompanied and supervised by a person who has held the class of licence for the heavy vehicle you want to drive, or a higher class of driver licence, for one year or more. You may also need a National Driver Work Diary, see section 3 Driver management.

If you want to upgrade your driver licence you need to:

- pass a knowledge test
- pass an eyesight test
- pass either a Driving Test or a HVCBA.

## Heavy Vehicle Competency Based Assessment (HVCBA)

---

Under HVCBA you have to demonstrate that you can perform certain skills or criteria to an RTO driving assessor. Your assessor records your performance in a log book and once you have successfully completed all the required criteria you can apply to upgrade your licence.

### HVCBA assessment while you learn

You can learn to drive either with a licensed driving instructor or with an appropriate NSW licence holder. You can only be assessed by an accredited RTO assessor. All assessors are licensed driving instructors so they can assess and train you.

For more information about HVCBA visit [nsw.gov.au](https://www.nsw.gov.au)

You must hold a current NSW driver licence to be eligible for HVCBA. HVCBA is the main way to get a heavy vehicle licence in Sydney, Central Coast and Newcastle regions.

## Knowledge test

---

The knowledge test assesses what you know about the general road rules as well as rules which relate only to heavy vehicles. For more information about knowledge tests visit **nsw.gov.au**

You must pass a heavy vehicle knowledge test before you can:

- get a Heavy Vehicle Competency Based Assessment Learner's Log Book to do HVCBA
- book a Heavy Vehicle Driving Test.

If you are learning, you can start to drive straight away on your current licence, but you must pass a heavy vehicle knowledge test before booking a Driving Test or getting a HVCBA Learner Log Book. The knowledge test pass is valid for 36 months.

## Driving Test

---

When you are ready for the Driving Test book and pay:

- online at **service.nsw.gov.au**
- by calling **13 22 13**
- at a service centre.

To change or cancel your booking, you must do this at least 24 hours before the test date or your fee may not be transferred or refunded.

The test vehicle must be registered and roadworthy. All heavy vehicles (except buses and coaches used for the Driving Test) must have a complying (approved and in working condition) lap-sash retractable seatbelt fitted to the front left passenger seat for the safety of the testing officer.

The Driving Test can be conducted in most vehicles authorised for the licence class you are applying for. However, for a licence class HR or HC Driving Test there are minimum standards for these testing vehicles. Vehicles not meeting these standards will not be accepted for a Driving Test.

All heavy vehicles, except buses, presented for the Driving Test must be loaded to at least 75 per cent of the maximum mass allowable for the vehicle to be driven on public roads.

This is at least 75 per cent of the 'legal mass limit'.

Also, if you pass a Driving Test in a vehicle fitted with an automatic or synchromesh gear box you will be restricted to driving these types of vehicles. To have this condition removed you need to pass a Driving Test in a vehicle fitted with a non-synchromesh gear box. To make sure you have all the information you need about vehicles for the test, visit [nsw.gov.au](https://www.nsw.gov.au)

## Manoeuvres

The Driving Test assesses your ability to drive safely and competently. During the test you will be required to perform certain manoeuvres. The following chart shows which manoeuvres are conducted for the various licence classes and types.

## Fail and immediate fail items

During the test, you can be failed for doing anything that is unsafe or against the law.

### Test manoeuvres by licence class and type

	<b>LR truck</b>	<b>LR bus</b>	<b>MR truck</b>	<b>MR bus</b>	<b>HR truck</b>	<b>HR bus</b>	<b>HC</b>
<b>Long reverse</b>	No	No	Yes	Yes	Yes	Yes	Yes
<b>Bus stop skills</b>	No	No	No	Yes	No	Yes	No
<b>Reverse park</b>	Yes	Yes	Yes	Yes	Yes	Yes	Yes
<b>U-turn (three-point turn)</b>	Yes	Yes	No	No	No	No	No
<b>Kerbside stop</b>	Yes	Yes	Yes	Yes	Yes	Yes	Yes
<b>Pre-departure check</b>	No	No	Yes	Yes	Yes	Yes	Yes
<b>Coupling or uncoupling</b>	No	No	No	No	No	No	Yes

## National Heavy Vehicle Driver Licence

The National Heavy Vehicle Driver Licence was introduced in the interests of road safety. It provides a driver with a single licence for all states. Points accumulated for traffic offences in any state count against your home state record.

You will be given a national licence when you are licensed to drive one of the following vehicles:

- a truck over eight tonnes GVM with three or more axles
- a bus over eight tonnes GVM with three or more axles.

# Driver management

Driving a heavy vehicle can be demanding. It is important to abide by the driver fatigue laws and regulations and generally take care of your health, in the interest of public safety and your own wellbeing.

A heavy vehicle driver spends a lot of time on the road. The work is demanding and you are responsible for heavy loads, dangerous goods and passengers. It is very important that you are in good health for your own safety and that of the public.

## Health of professional drivers

---

The most important ways to stay healthy and keep on top of your job are:

- get enough sleep
- eat a well-balanced diet
- exercise regularly
- try to relieve stress.

### Enough sleep

The need for sleep varies among individuals with some people needing more sleep than others. Make sure that you get most of your sleep at night time – it is better than daytime sleep. Regular night sleep of about seven to eight hours is one of the best ways to manage driver fatigue.

### Diet and exercise

To stay fit and healthy for your job your weight needs to be within an acceptable range. Eating the right foods and taking regular exercise is the only answer. Ask your GP for advice or check these websites for information: **[ntc.gov.au](http://ntc.gov.au)** and **[austroads.com.au](http://austroads.com.au)**

### Try to relieve stress

Stress affects your driving. If you are having problems at home or at work, you are up to five times more likely to be involved in a crash. Your GP can advise you on where to go for help.



# Driver fatigue

Driver fatigue is one of the biggest causes of crashes for heavy vehicle drivers. In NSW, at least eight per cent of heavy truck fatal crashes involve a fatigued heavy vehicle driver. Many of these crashes occur late at night or early in the morning.

As a professional driver, you need to understand what causes fatigue and how to pick up on the early warning signs so that you can do something about it before it affects your driving.

## Causes of fatigue

---

### Sleep

- Getting less sleep than you need
- Getting less sleep than you need over a number of days
- Trying to sleep during the day.

### Time of day

- Working when you should normally be asleep
- Working in the early hours of the morning
- Working in the early afternoon after a heavy lunch
- Sleeping during the day when you would normally be awake.

### Work

- Long driving hours
- Night time driving
- Irregular hours and early starting times
- Tight scheduling
- Insufficient time to recover from previous work
- Doing non-driving physical work such as loading and unloading
- Poor driving conditions such as hot or wet weather
- Monotonous driving.

### Physical

- Poor health and fitness
- Emotional issues
- Medical sleep problems.

## Signs of driver fatigue

---

Driver fatigue severely impairs your concentration and judgment; it slows your reaction time. Watch for these early warning signs of driver fatigue:

- yawning
- poor concentration
- tired or sore eyes
- restlessness
- drowsiness
- slow reactions
- boredom
- feeling irritable
- making fewer and larger steering corrections
- missing road signs and taking wrong turns
- having difficulty staying in the lane
- microsleeps where you 'nod off' for a short time.

## Tips to manage driver fatigue

---

- Resting and sleeping are the two most important ways to combat fatigue. Have a good night's sleep before you start your trip, and even have an afternoon nap before starting back on a night shift. You can also take rests early on in the trip before you start feeling fatigued.
- Plan your trip ahead of time to allow for rest breaks.
- Plan your rest breaks to happen before you start feeling fatigued, or plan where to stop if you do start to feel fatigued. If you can, plan rest breaks for when your body clock will tell you to be asleep (ie afternoon, night/early morning) because that is when you are most likely to become fatigued.
- Try and have a regular sleep and waking schedule on every day -of the week.
- Be aware of the causes and effects of fatigue and recognise the early warning signs. Make sure you stop and rest as soon as possible when you realise you are becoming fatigued. Do not try and push on, especially in those 'body clock' danger times of night/early morning and afternoon.

- Have at least two nights of unrestricted sleep to repay 'sleep debt' to become completely refreshed.
- Look after your health and fitness with regular exercise and a healthy diet.
- Never drink alcohol before or during your trip.
- Never drive longer than the legal work and rest hours, or agree to a roster that is longer than the legal work and rest hours.

## Roadside rest areas

---

Rest areas are available 24 hours a day, every day of the year and signposted. Service centres, petrol stations, parks and country towns are other places you can stop and take a break from driving. The NSW Rest Areas road map shows truck stop locations, it is also a guide to all major trucking routes across the state. The map is available at [roads-waterways.transport.nsw.gov.au](https://roads-waterways.transport.nsw.gov.au)

## National Heavy Vehicle (Fatigue Management)

---

The Heavy Vehicle National Law (NSW) and the Heavy Vehicle (Fatigue Management) National Regulation (NSW) contain provisions relating to the management of heavy vehicle driver fatigue. The legislation applies to drivers of fatigue regulated heavy vehicles and to parties in the supply chain whose activities influence the conduct of heavy vehicle drivers in such a way as to affect the driver's fatigue. The National Regulation sets the maximum hours of work and minimum rest periods for drivers of 'fatigue regulated heavy vehicles'.

A 'fatigue regulated heavy vehicle' is a:

- heavy truck with a Gross Vehicle Mass (GVM) of more than 12 tonnes
- truck and trailer combination, if the combined GVM is more than 12 tonnes
- bus with a GVM of more than 4.5 tonnes that seats more than 12 adults (including the driver).

## Driver fatigue and workplace health safety

---

### Work

Work limits are like speed limits. They state the maximum time allowed in ideal conditions. That is, when drivers are well rested and alert. If you are likely to be fatigued for any reason you must not drive a fatigue-regulated heavy vehicle.

Work time is not just driving time.

Work refers to the time that the driver spends driving a fatigue-regulated heavy vehicle whether or not it is on a road and any other time spent on tasks related to the operation of the vehicle. Driving includes being in the driver's seat while the engine is running and instructing or supervising the driver of the vehicle. Work time also includes:

- Loading and unloading the vehicle
- Inspecting, servicing or repairing the vehicle
- Inspecting or attending to the load on the vehicle
- Attending to passengers of a bus
- Cleaning or refuelling the vehicle
- Performing marketing tasks in relation to the operation of the vehicle. Marketing tasks include arranging for the transport of passengers or goods as well as canvassing for orders for the transport of passengers or goods
- Recording information.

Work time is a maximum period so is always rounded upwards, for example a period less than 15 minutes is counted as 15 minutes work, a period more than 15 minutes up to 30 minutes is counted as 30 minutes work etc.

### Rest

All other time is counted as rest. The rest requirement is a minimum period. If you feel fatigued, you will need more rest. When you feel tired, stop, take a break or have a sleep. Rest is always rounded downwards, for example a period less than 15 minutes does not count towards rest while a period of 15 minutes but less than 30 minutes is counted as 15 minutes rest etc.

## Chain of responsibility

---

The Heavy Vehicle National Law (NSW) requires all parties in the supply chain to take all reasonable steps to prevent fatigue of heavy vehicle drivers.

For example, this means that:

- drivers must stop the vehicle if feeling tired or fatigued
- operators and schedulers must plan when drivers can take a rest
- loading managers must take steps to ensure queuing is managed properly
- contracts must not be prepared that require drivers to break the law.

Parties in the supply chain include the:

- employer of the driver of the vehicle
- prime contractor of the driver
- operator of the vehicle
- scheduler of goods or passengers for transport by the vehicle, and the scheduler of its driver
- consignor of goods for transport by the vehicle
- consignee of goods for transport by the vehicle
- loading manager of goods for transport by the vehicle
- loader of goods on to the vehicle
- unloader of goods from the vehicle.

Your vehicle is your workplace.

Any vehicle used by employees in the course of their employment is defined as their workplace, including heavy trucks or buses.

## Work and rest options

---

Under the National Regulation, industry has a choice of operating under three fatigue management schemes. Each option allows increasing levels of flexibility which are offset by managing risks through accreditation schemes.

The tables that follow set the maximum work and minimum rest requirements provided in the National Regulation.

In a period referred to in column one, a driver must not work for more than the period referred to in column two. A driver must also have a total rest time for a period of not less than the time referred to in column three.

### Standard Hours

The Standard Hours option is aimed at regular scheduled operations with a lower fatigue risk with up to 12 hours work in any period of 24 hours.

**TABLE 1 STANDARD HOURS  
SOLO DRIVERS OF A FATIGUE-REGULATED  
HEAVY VEHICLE**

<b>Total period</b> In any period of...	<b>Maximum work time</b> A driver must not work for more than a total of..	<b>Minimum rest time</b> And must have at least...
5 hours and 30 minutes	5 hours and 15 minutes	15 continuous minutes rest
8 hours	7 hours and 30 minutes	30 minutes rest, in blocks of 15 continuous minutes
11 hours	10 hours	60 minutes rest, in blocks of 15 continuous minutes
24 hours	12 hours	7 continuous hours stationary <sup>1</sup> rest
7 days (168 hours)	72 hours	24 continuous hours stationary rest
14 days (336 hours)	144 hours	4 night rests (includes 2 consecutive night <sup>2</sup> rests)

1. Stationary rest is rest time that a driver spends out of a heavy vehicle or in an approved sleeper berth of a stationary fatigue-regulated heavy vehicle.
2. A night's rest means 7 continuous hours taken between 10pm and 8am or 24 continuous hours stationary rest.

**TABLE 2 STANDARD HOURS FATIGUE MANAGEMENT  
SOLO DRIVER OF BUSES**

<b>Total period</b> In any period of...	<b>Maximum work time</b> A driver must not work for more than a total of...	<b>Minimum rest time</b> And must have at least...
5 hours and 30 minutes	5 hours and 15 minutes	15 continuous minutes rest
8 hours	7 hours and 30 minutes	30 minutes rest, in blocks of 15 continuous minutes
11 hours	10 hours	60 minutes rest, in blocks of 15 continuous minutes
24 hours	12 hours	7 continuous hours stationary <sup>1</sup> rest
7 days (168 hours)	N/A	6 x night rest <sup>2</sup> breaks
28 days (672 hours)	288 hours	4 x 24 continuous hours stationary rest

1. Stationary rest is rest time that a driver spends out of a heavy vehicle or in an approved sleeper berth of a stationary fatigue-regulated heavy vehicle.
2. A night's rest means 7 continuous hours taken between 10pm and 8am or 24 continuous hours stationary rest.



**TABLE 3 STANDARD HOURS FATIGUE MANAGEMENT  
TWO-UP DRIVERS OF A FATIGUE-REGULATED  
HEAVY VEHICLE**

<b>Total period</b> In any period of...	<b>Maximum work time</b> A driver must not work for more than a total of..	<b>Minimum rest time</b> And must have at least...
5 hours and 30 minutes	5 hours and 15 minutes	15 continuous minutes rest
8 hours	7 hours and 30 minutes	30 minutes rest, in blocks of 15 continuous minutes
11 hours	10 hours	60 minutes rest, in blocks of 15 continuous minutes
24 hours	12 hours	5 continuous hours stationary <sup>1</sup> rest or 5 continuous hours rest time in an approved sleeper berth while the vehicle is moving
52 hours	N/A	10 continuous hours stationary rest
7 days (168 hours)	60 hours	24 hours continuous stationary rest time and 24 hours stationary rest time in blocks of at least 7 continuous hours stationary
14 days (336 hours)	120 hours	4 night rests (includes 2 consecutive night <sup>2</sup> rests)

1. Stationary rest is rest time that a driver spends out of a heavy vehicle or in an approved sleeper berth of a stationary fatigue-regulated heavy vehicle.
2. A night's rest means 7 continuous hours taken between 10pm and 8am or 24 continuous hours stationary rest.

## Basic fatigue management (BFM)

BFM gives accredited operators greater flexibility in managing driver work and rest times, providing the risks of working long and night hours are managed. Before a driver can work BFM they must have been inducted into their operator's BFM fatigue management system and meet the requirements relating to drivers under accreditation.

The 36 hour rule manages the risk of working long hours in combination with night work. A driver can only work up to 36 'long and night' hours in any seven day period.

**TABLE 4 BASIC FATIGUE MANAGEMENT  
SOLO DRIVERS OF A FATIGUE-REGULATED  
HEAVY VEHICLE**

<b>Total period</b> In any period of...	<b>Maximum work time</b> A driver must not work for more than a total of..	<b>Minimum rest time</b> And must have at least...
6 hours and 15 minutes	6 hours	15 continuous minutes rest
9 hours	8 hours and 30 minutes	30 minutes rest, in blocks of 15 continuous minutes
12 hours	11 hours	60 minutes rest, in blocks of 15 continuous minutes
24 hours	14 hours	7 continuous hours stationary <sup>2</sup> rest
7 days (168 hours)	36 hours long/night <sup>1</sup>	N/A
14 days (336 hours)	144 hours	2 x 24 continuous hours stationary rest. First 24 hours rest must be taken after no more than 84 hours work. 4 nights off (including 2 consecutive)

1. Long/night hours means any work time in excess of 12 hours in any 24 hour period or between 12 midnight and 6am.
2. Stationary rest is rest time that a driver spends out of a heavy vehicle or in an approved sleeper berth of a stationary fatigue-regulated heavy vehicle.

**TABLE 5 BASIC FATIGUE MANAGEMENT  
TWO-UP DRIVERS OF A FATIGUE-REGULATED  
HEAVY VEHICLE**

<b>Total period</b> In any period of...	<b>Maximum work time</b> A driver must not work for more than a total of..	<b>Minimum rest time</b> And must have at least...
24 hours	14 hours	
82 hours	N/A	10 continuous hours stationary <sup>1</sup> rest time
7 days (168 hours)	70 hours	24 hours continuous stationary rest time and 24 hours stationary rest time in blocks of at least 7 continuous hours
14 days (336 hours)	140 hours	4 x 7 continuous hours stationary rest time between 10 pm on a day and 8am on the next day, using the time zone of the base of the driver.

1. Stationary rest is rest time that a driver spends out of a heavy vehicle or in an approved sleeper berth of a stationary fatigue-regulated heavy vehicle.

## Advanced Fatigue Management (AFM)

AFM hours are more flexible and less prescriptive than either Standard Hours or BFM hours. Drivers may work AFM hours when they have been inducted into their operator's AFM fatigue management system and meet the requirements relating to drivers under accreditation. Operators must specify the normal operating limits under which their drivers will usually work.

**TABLE 6 ADVANCED FATIGUE MANAGEMENT OUTER LIMITS**

<b>Total period</b> In any period of...	<b>Maximum work time</b> A driver must not work for more than a total of...	<b>Minimum rest time</b> And must have at least...
24 hours	15½ hours work time	7 continuous hours stationary* rest time
14 days (336 hours)	154 hours work time	30 continuous hours stationary rest time that includes the periods 12am to 6am on a day and 12am to 6am on the following day, using the timezone of the driver's base.
28 days (672 hours)	288 hours work time	N/A

\* Stationary rest is rest time that a driver spends out of a heavy vehicle or in an approved sleeper berth of a stationary regulated heavy vehicle.

## National driver work diary

---

Drivers of fatigue regulated heavy vehicles that are required to carry and fill in a work diary must record their work and rest times.

Drivers must record information such as whether they are working under Standard Hours, BFM hours or AFM hours and when they change from work and rest option in their work diary.

The new work diary is available from a service centre.

## Completing your work diary

---

You must record all work and rest time in your work diary unless operating under an exemption. These records must be completed for the whole trip. The work diary must show:

- your name
- driver licence number
- accreditation number (if applicable)
- fatigue management option under which the driver is operating
- date and day of week
- time zone (driver base).

You must also record:

- work and rest hours
- number plate (record at start and end of day and vehicle change).
- odometer reading (record at start and end of day and at each work and rest change if the odometer reading changes and if there is a vehicle change)
- name of location at each work and rest change (rest area, truck stop, suburb or town)
- total number of hours of each activity at the end of the day
- when the page is completed, sign the daily sheet to certify that the entries are correct.

Visit [nhvr.gov.au](http://nhvr.gov.au) for information and examples on how to complete a National Driver Work Diary.

If you are a two-up driver or become a two-up driver, you must record the:

- other driver's name
- other driver's licence number and State or Territory where issued
- security or identifying number of the other driver's work diary
- two up driver's signature.

You must use the work diary pages in strict order from start to finish. You must be able to produce your last 28 days driving records. You must give your record keeper the duplicate copies of your work diary within 21 days. If you have more than one employer in a single day, you must also give the other record keeper a copy of your work diary page. Record keepers must keep copies of work and rest records for a period of three years.

## Looking after your work diary

---

The work diary is issued to you personally and it is an offence to:

- let anyone else use or borrow it
- have more than one work diary containing pages which have not been used or cancelled
- remove the application page or any original pages
- alter, deface or destroy any page
- make any false entries.

Carry and complete your work diary at all times. You must be able to produce your driving record for the last 28 days.

## Driver base

---

The driver base is the place from where the driver normally does the work.

## Alcohol, drugs and professional drivers

It is illegal to drive while under the influence of alcohol or drugs, including some over-the-counter and prescription medicines.

### Alcohol and driving

---

Alcohol is a depressant and reduces your ability to drive safely because it:

- slows brain functions so that you can't respond to situations, make decisions or react quickly
- reduces your ability to judge speed and distance
- gives you false confidence that leads to taking risks
- makes it hard to do more than one thing at a time
- affects your sense of balance and coordination
- makes you sleepy.

### Getting back to zero

---

After a night of heavy drinking, it can take more than 18 hours for your blood alcohol concentration (BAC) level to get back to zero. Many people are booked for drink driving the day after.

### What does not sober you up

---

- A cup of black coffee.
- A cold shower.
- Fresh air.
- Mints or chewing gum.
- Milk.
- A short nap.
- Vomiting.

These things have no effect on your blood alcohol level. Once you have had a drink, you just have to wait it out.

Your BAC must be under .02 when you drive a:

- heavy vehicle with a GVM of more than 13.9 tonnes
- public passenger vehicle such as a bus or a coach
- vehicle which carries a dangerous load.

Even one drink can put you over the legal limit.

You need to take into account any drinks you have had.

It takes the body an hour or more to get rid of the alcohol from one standard drink.

## Drugs and driving

---

A drug is any chemical substance that alters the normal way that your body or mind works. Drugs not only affect your physical skills such as reaction times, coordination and vehicle control but also affect your mood, perception, information processing and risk taking behaviour. That is why drugs can make your driving worse and greatly increase your chance of having a crash.

How a drug will affect you depends on:

- the drug itself – type, amount, purity and method of use
- your weight, body size and health
- other drugs you have taken, and the setting such as surroundings and work situation.

Whatever drug is used, it is important that you know how it affects you, the harm it can do and what it does to your body.

Generally heavy vehicle drivers who do take drugs take two types – stimulants to try and stay awake and depressants to try and go to sleep.

### Stimulants

**Stimulants** (uppers) speed up messages between the brain and the body. They include medicines with mild stimulants like pseudoephedrine and illegal drugs like speed.



## Stimulants and driving

Stimulants do not increase your driving ability or coordination, however, they can:

- give you a false sense of confidence
- increase your risk taking behaviour
- distort your visual perceptions making it difficult to judge distances
- make you feel exhausted because you cannot sleep which will affect your reflexes and your concentration
- increase your risk of having a crash.

As the effects of stimulants begin to wear off, you may experience a level of fatigue that is worse than when you first took the drug.

The long-term health effects of taking stimulants include:

- anxiety
- chronic sleep problems
- compulsive repetition of actions
- depression
- extreme mood swings
- high blood pressure
- heart failure
- impotence
- irritability
- panic attacks or seizures
- paranoia
- suspiciousness
- weight problems.

Taking drugs to keep awake can make fatigue worse when the effect of the drug wears off.

A good sleep is the only way to prevent or cure fatigue.

## Depressants

**Depressants** slow your reflexes, impair your balance and coordination, affect your vision and perception of time and space, your memory and your ability to think logically. The ‘hangover’ effects such as drowsiness and poor coordination can last for several hours after the initial effects, which can mean you are not able to drive safely.

Depressants greatly increase the risk of having a crash when you are driving because you can have:

- slower reaction time
- distorted perception of speed and distance
- impaired vision
- reduced ability to concentrate
- impaired coordination and decreased ability to coordinate the appropriate reaction when driving.

## Prescription drugs

Some prescription medications can affect your driving. Read the instructions on the packaging or consult your doctor or pharmacist to find out if the drugs you are taking would impair your driving ability.

## Drug testing

---

### Roadside drug testing

Police now have the powers to carry out roadside drug testing on any driver, rider and supervising licence holder in NSW. Specific Police drug testing operations will target heavy vehicle drivers.

### Driving under the influence of drugs

If the manner of your driving indicates that you are impaired by drugs or you are involved in a fatal crash, Police have the power to take you to hospital to obtain a blood and urine sample. The sample will be analysed for any drug, including some prescription drugs known to impair driving.

## Seatbelts

It is important for truck and bus drivers to wear a seatbelt. Any driver or passenger must wear a seatbelt properly adjusted and securely fastened wherever there is one available. If there is an empty seat with a seatbelt, a passenger must move to that seat. The driver will not be penalised if there is no seatbelt and the vehicle has been manufactured before the requirement for seatbelts commenced.

Compulsory seatbelt laws have been in place for heavy vehicle drivers since 1 February 2000.

Vehicles that have been modified by the installation of non-original seats (eg driver's suspension seat) must have suitable seatbelts in order for those vehicles to comply with mandatory equipment requirements and provide the driver with a suitable level of comfort.

It is an offence to remove a fitted seatbelt from a vehicle.

### The driver is responsible

Drivers (other than bus drivers) have a responsibility under the Road Rules to ensure all passengers, particularly children, are being properly restrained in a seatbelt or approved child restraint where seat belts are fitted. There are fines and demerit points for a driver who is not wearing a seatbelt and who fails to ensure that passengers use seatbelts.

Passengers aged 16 years and over who do not use an available seatbelt can also be individually fined.

## Entering and exiting a vehicle

For safety there is a procedure for entering and exiting a heavy vehicle.

To enter the vehicle the driver must check for traffic before moving out from the line of the vehicle and again before opening the door. When entering the vehicle the driver must use available steps and grab handles to climb into the vehicle, maintaining three points of contact at all times.

To exit the vehicle the driver must check again for traffic before opening the door. When exiting the vehicle the driver must exit facing the vehicle using available steps and grabs (not jumping) while maintaining three points of contact.

Route bus drivers also need to be aware of this procedure.

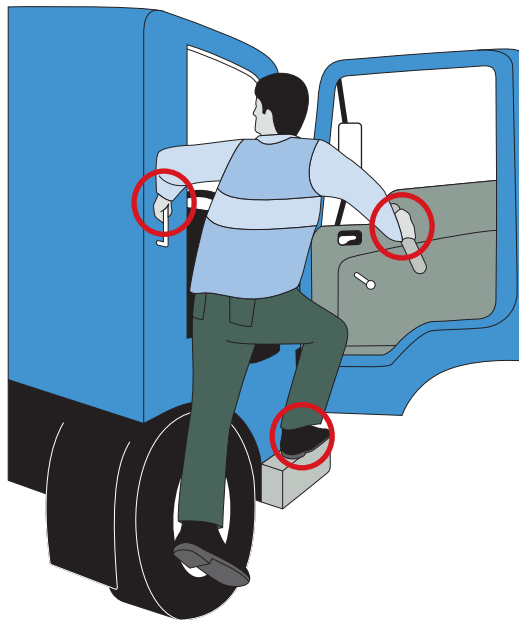

# Safe driving

## Low risk driving

As a professional driver you should at all times display 'low risk' driving. Know how to control your vehicle, show respect for other road users and only drive when you are alert.

Driving is never risk free, but you should aim to drive 'low risk'. A low risk driver has good observation, speed management and road positioning skills. The Road User Handbook explains low risk driving in detail.

### Observation

---

The key to good observation is scanning.

### Speed management

---

Drive at a speed that is within the speed limit and that will allow you to react and completely stop within the distance you can see is clear. When you see potential hazards, slow down and prepare to stop. If you cannot see at least five seconds ahead you must slow down. Slow down on wet, icy or gravel roads where it will take longer for your vehicle to stop.

### Road positioning

---

Position your vehicle to maximise the distance from hazards (this is also referred to as buffering). For example, moving left at the crest of a hill to create space from oncoming vehicles, or moving away from a parked car to avoid doors opening and pedestrian movement.

### Crash avoidance space

---

A low risk driver maintains a crash avoidance space completely around the vehicle. The crash avoidance space is managed by adjusting the vehicle's speed and road position.

To determine the crash avoidance space to the front of the vehicle you need to take into account two key factors – reaction time and response time.

**Reaction time** is the time the driver needs to:

- see and understand the situation
- decide on a response
- begin to take action.

A heavy vehicle driver who is fit, alert and not affected by alcohol, drugs or fatigue, needs about 1.5 seconds to react to a hazard. At higher speeds it increases to about 2.5 seconds.

**Response time** is the time required to take action. Most people need at least 1.5 seconds to respond. In many situations braking may be the only possible response. Swerving is rarely appropriate and can result in a more severe crash, for example a head-on collision.

In good driving conditions, most heavy vehicle drivers need at least a 4-second crash avoidance space (often called a 4-second gap) to react and respond to situations safely and avoid a crash.

The 4-second gap can be used when following another vehicle or if there is potential for something to move into your crash avoidance space.

### Four-second crash avoidance space

To calculate a 4-second crash avoidance space when following another vehicle use this basic technique: as the rear of the vehicle in front of you passes an object at the side of the road such as a power pole, tree or sign, start a 4-second count 'one thousand and one, one thousand and two, one thousand and three, one thousand and four'.

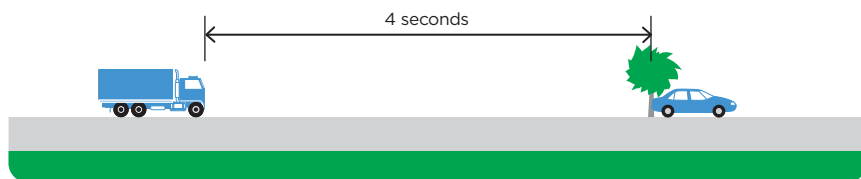

If your vehicle passes the object you picked before you finish the 4-second count, you are following too closely. Your crash avoidance space is not large enough. Slow down, and repeat the count again until the 4-second crash avoidance space is achieved.

You should increase your crash avoidance space to 5 or more seconds when driving in poor conditions, such as on unsealed (dirt or gravel), icy or wet roads, or at night.

## Potential for something to move into the crash avoidance space

The 4-second gap can also be used for situations where there is potential for something to move into the crash avoidance space, for example, a car in an adjacent street could fail to give way and pull out. Low risk drivers experienced in maintaining a 4-second following distance are able to mentally judge a 4-second crash avoidance space in front of their vehicle. If there is potential for a hazard to enter this crash avoidance space, reduce your speed and create a buffer. It is necessary to maintain the crash avoidance space for all potentially hazardous situations, including blind corners and crests.

Many of the crashes that occur each day in NSW could be avoided if drivers actively maintained their crash avoidance space.

## Legal minimum distances between large vehicles

A road train that is travelling behind a long vehicle (a vehicle 7.5m or longer) must maintain a minimum following distance of 200m. All other long vehicles travelling behind another long vehicle must maintain a minimum following distance of 60m. This minimum following distance requirement does not apply on multilane roads, in built up areas or when overtaking.

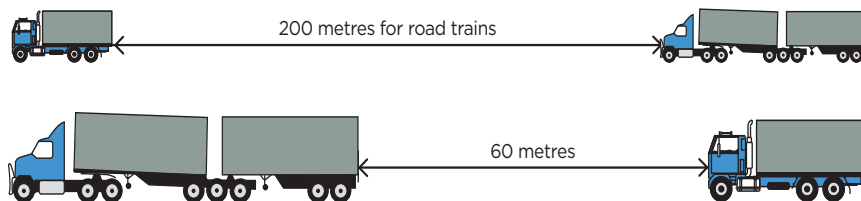

**Legal requirements.** By law large vehicles must maintain the minimum or greater following distance.

If another law prescribes a different minimum following distance the driver of a road train or other long vehicle must comply with that requirement.

## Vehicle controls

---

### Spring brakes or 'maxi-brakes'

Most fully air-braked vehicles on the road are equipped with spring-loaded parking brakes. These brakes rely on air pressure to hold them in the OFF position.

### Trailer brake

Some vehicles are fitted with a hand operated trailer brake. This is a separate valve operated by hand which applies the trailer brake independently of the footbrake. **The trailer brakes must not be used for normal braking** as they will wear, overheat or burn out, and lose their effectiveness completely. A trailer with ineffective brakes attached to a towing vehicle with effective brakes can cause it to jack-knife or rollover if it brakes heavily.

A trailer hand brake may be applied if necessary to prevent the vehicle from rolling backwards and to avoid transmission shock load when moving off on a hill. Trailer brakes are not parking brakes and should not be used as such.

### Controlling speed

- Brake early and gradually.
- Where possible, brake when your vehicle is driving in a straight line.
- Allow for the weight of the load – a loaded vehicle takes far more braking effort to slow down than an unloaded one.
- Brake according to the road surface – allow more braking distance if the road is gravel, steep or slippery.
- Ease off the brakes as the vehicle slows down.
- Always test the brakes immediately after driving through deep water as wet brakes do not perform well.



The service brake should be used under all normal conditions.

## Brake failure

Brakes kept in good condition rarely fail. Most brake failures occur because of:

- loss of air pressure
- loss of hydraulic pressure
- brake fade (boiling of hydraulic fluid) on long hills
  - bad driving practice
- poorly maintained brakes.

## Jack-knife and trailer swing

You can reduce the chances of jack-knife or trailer swing by making sure that all brakes and tyres are in good condition and that the load is evenly distributed between axle groups. You should be especially careful in wet weather.

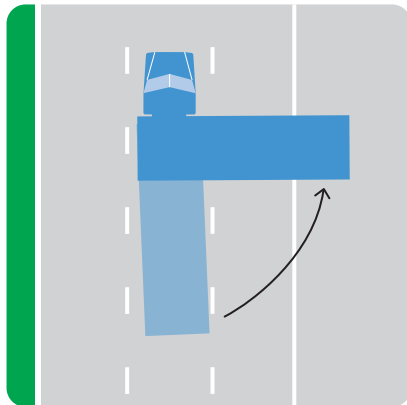

Trailer swing is where the trailer slides prime dangerously.

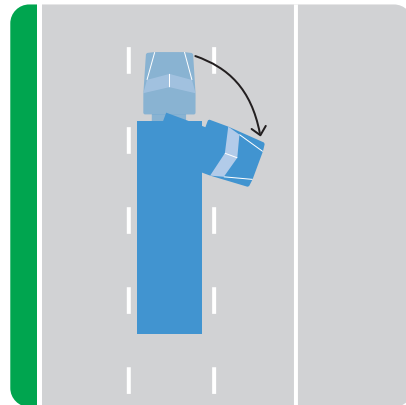

A jack-knife is where the trailer and mover lock against each other.

## Railway level crossing safety

You must not drive onto a level crossing when a train is approaching or if the road on the other side is blocked.

Know the length of your vehicle. Look ahead, make sure there is enough room, so you do not have any part of your vehicle hanging over the tracks.

When driving heavy vehicles or buses near a level crossing you should:

- allow extra time for your long vehicle to clear the tracks
- look both ways for trains, especially at roads on an angle to the tracks, as the cabin view from the left side is limited
- be careful not to damage level crossing signs and signals
- be aware of long aerials and load height so you can safely clear overhead electrified wiring
- check **roads-waterways.transport.nsw.gov.au** for Restricted Access Vehicle (RAV) maps and lists
- check ground clearance so you do not get stuck or damage tracks.

If your vehicle becomes stuck on a level crossing, leave it, get to a safe place, and call the police on triple zero **000**.

If you damage a level crossing sign or signal you must report it to the relevant state rail authority.

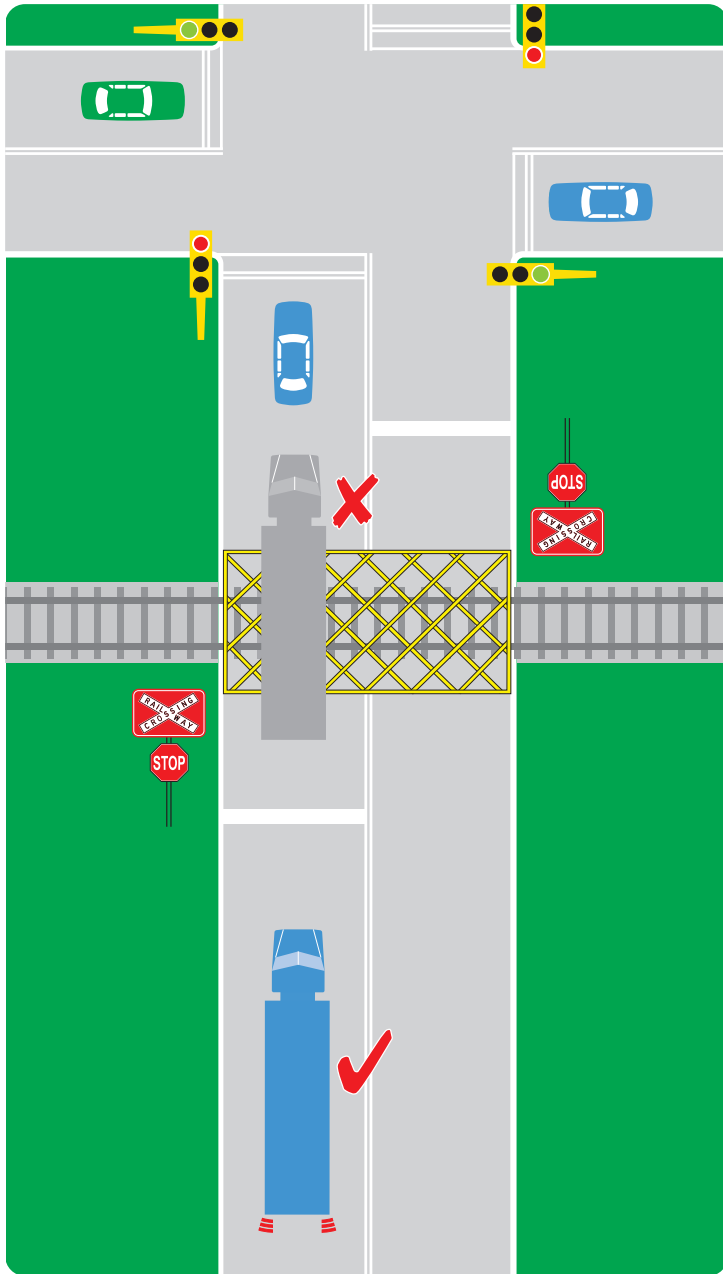

Do not stop on a level crossing, allow a safe stopping space away from the tracks.

## Loss of pressure in air brakes

Whenever you drive, make sure there is enough air pressure for at least five brake applications. Air brakes can fail because of a leak in the air lines or over-use. **Stop immediately** if the low air pressure warning device comes on. You should stop by gearing down until the vehicle is slow enough to apply the brakes.

Most vehicles fitted with full air system brakes are usually fitted with spring parking brakes, also known as maxi-brakes, where air pressure is required to keep them off.

On some older vehicles the spring brakes may come on when the air pressure is very low. You should monitor the air pressure gauges often as low air pressure can happen anytime. When the gauge shows low air pressure, release the brakes at least twice, so you can move the vehicle to a safe area.

## Loss of hydraulic brakes

What to do if your hydraulic brakes fail:

- change gears down
- pump the brakes – sometimes pumping them can partially restore hydraulic brakes
- use the emergency parking brake.

# Basic driving techniques

## Hills

---

### Before going down a hill

Reduce speed and select the correct gear before beginning the descent. It is very important to select a gear low enough to slow down the vehicle.

Do not try to change gears while going downhill as you can lose control of the vehicle. If you try to gear down but you miss the gear, stop the vehicle with the brakes immediately, then select the correct gear. Attempting to coast while you struggle with the gears is very dangerous.

### Braking going down hills

Brake failure can be prevented by good driving techniques.

If you use the brakes to slow a vehicle travelling downhill it can cause overheating. This leads to brake fade, or brake burn-out in which the brake linings completely lose their grip and are no longer effective.

### Going down hills

- Select a gear low enough to slow down the vehicle without the constant use of brakes.
- If you miss the gear when trying to gear down, stop the vehicle with the brakes immediately, then select the correct gear. It is very dangerous to coast while you struggle with the gears.
- Use auxiliary brakes to help control the vehicle speed.
- Reserve your service brakes for coping with emergencies, traffic conditions or sharp corners.

- Try to brake on straight sections of road where possible as this reduces the chance of skidding.
- Avoid fanning (repeatedly applying and releasing) the brakes as this leads to an increase in brake temperature and failure due to brake burn out. In air brake systems, fanning wastes compressed air, reducing the reserve available for an emergency.

### Going up hills

- Shift down early to prevent engine ‘lugging’. Lugging is shuddering or excessive vibration in the engine.
- Use engine torque (the turning force available at the crankshaft) efficiently. Do not let engine revs fall below the maximum torque speed.
- Shifting down two or more gears at once may be necessary when going up a steep hill.

### Before entering a sharp curve

---

Reduce speed and select the correct gear before you enter the curve. The gear you select should have the engine revs near the maximum torque level as specified by the engine manufacturer, allowing you to accelerate smoothly out of the turn.

### Slowing and stopping

---

When slowing or stopping a heavy vehicle it is best to use your brakes only. However, when driving down a steep hill it may be necessary to remain in a low gear to control the vehicle’s speed.

Never drive out of gear. This is extremely dangerous and can lead to loss of vehicle control and overheated brakes.

You must select a low gear before starting a steep descent.

## Animals and vehicles

---

A driver or passenger must not lead an animal including by tethering while the vehicle is moving.

Animals that are being transported must be seated or housed in appropriate areas. Drivers must not drive with an animal in the driver's lap.

# Heavy vehicle road rules

As a professional driver it's your responsibility to know the road rules that apply to all vehicles, especially heavy vehicles.

## Speed limits

---

In NSW the maximum speed limit for a vehicle that exceeds a GVM of 4.5 tonnes is 100km/h.

For certain road conditions (eg sharp bend, steep descent, winding road), special speed limit signs may be posted for trucks, road trains and buses. You must not drive at a speed greater than the speed shown on the sign.

## Speed limiters

Speed limiters are devices that limit a vehicle's maximum speed. If your vehicle falls into one of the following groups, it must be speed limited to 100km/h.

A heavy vehicle or bus manufactured on or after 1 January 1988, being either a:

- truck having a GVM exceeding 15 tonnes
- bus used to provide a public passenger service and with a GVM exceeding 14.5 tonnes.

A heavy vehicle or bus manufactured on or after 1 January 1991 being either a:

- truck having a GVM exceeding 12 tonnes
- bus used to provide a public passenger service and with a GVM exceeding five tonnes.

## Speeding compliance

The speeding compliance provisions of the Heavy Vehicle National Law (NSW) places duties on parties in the supply chain to take all reasonable steps to ensure that their business activities, schedules or arrangements do not cause heavy vehicle drivers to exceed an acceptable speed limit.



These requirements complement existing chain of responsibility provisions for mass, load restraint, vehicle dimension and fatigue management, and apply to heavy vehicles with a gross vehicle mass of more than 4.5 tonnes.

## Parties in the chain

There is a specific duty on seven off road parties to take all reasonable steps to ensure that their actions do not cause drivers to exceed speed limits. The parties in the chain include:

- employers
- prime contractors
- operators
- schedulers
- loading managers
- consignors
- consignees.

It is the performance of any of these functions that determines whether a person falls into one of the above categories rather than their job title or description.

In addition, a person may be a party in the chain in more than one capacity.

## Heavy vehicle drivers

The Regulation does not impose any obligations on employed drivers. Drivers of heavy vehicles are required to obey the speed limits. Penalties on drivers failing to comply with speed limits include demerit points, licence suspension, cancellation or disqualification and fines.

## Driving in wet conditions

---

Wet roads reduce tyre grip and can result in loss of control.

You should drive at a speed that allows you to brake gradually and stop within the distance you can see. The safe speed for your vehicle and its load may be much lower than the posted speed limit.

To avoid skidding, slow down when approaching corners and select an appropriate gear to maintain vehicle control without the need for braking.

## Intersections

---

At intersections you may have to swing wide to make a left turn. At marked intersections:

- position your vehicle so that any vehicles behind cannot pass on your left
- position yourself to get the best view possible of the road you are turning into.

Bus and truck drivers need to start a left turn further into the intersection than a car so that the back wheels do not run over the kerb.

### Crossing or entering traffic

You must choose a suitably large gap in the traffic to get across an intersection, enter a new street or merge with traffic.

Consider the size and weight of your vehicle when crossing or entering intersections, changing lanes, and making other manoeuvres. Also remember that a loaded vehicle will accelerate slower than an empty one.

Before moving from a stationary position at the side of the road or a median strip parking area, you must signal for at least five seconds, check mirrors and blind spots.

## Turning

Trucks and buses need more space to turn wide or cut into traffic so allow enough space on either side of your vehicle to avoid sideswiping other road users or objects.

### Turning right from a one way street

A vehicle (or vehicle and trailer) that is 7.5m or longer and has a DO NOT OVERTAKE TURNING VEHICLE sign displayed on the back, can turn right from the lane on the immediate left of the far right lane.

Plan your turn early so that you are in the correct part of the intersection and you have time to signal. Avoid turning too soon because the side of your vehicle may hit vehicles on your right as the back of your vehicle cuts in to the turn.

In a road with two right turn lanes, always use the turning lane on the far left.

A vehicle of 7.5m or longer may display the words DO NOT OVERTAKE TURNING VEHICLE on one of the rear marking plates.

If your vehicle (or vehicle and trailer) is under 7.5m long, you must not display this sign on the back, and you must turn within the lanes marked on the road at all times.



DO NOT OVERTAKE TURNING VEHICLE

## Reversing

---

When reversing a heavy vehicle, you must:

- Activate hazard warning lights before starting to reverse
- Avoid unnecessary reversing. Plan ahead to use the shortest possible reversing distance
- Use a helper to guide you whenever possible. You should be able to see the guide who should have a clear view of where your vehicle is going
- Get out and have a look if you are not sure what is behind you
- Always reverse your vehicle into position in a driveway or loading dock.

Although you may need to hold up traffic while you reverse, it is much safer to drive forward into traffic as you leave.

## Overtaking

---

There are special problems associated with overtaking while driving a heavy vehicle.

It is very important to watch for small vehicles, such as motorcycles and bicycles. Before pulling out, check your mirrors and glance down to check for vehicles below your cabin. Air movement caused by a large vehicle travelling fast can force a small vehicle off the road, or draw it into the side of a larger vehicle.

When passing or overtaking a bicycle rider, you must allow a distance of at least:

- 1m when the speed limit is 60km/h or less
- 1.5m when the speed limit is more than 60km/h.

In order to provide the minimum safe passing distance to a bicycle rider, drivers are exempt from certain road rules. These exemptions allow drivers to drive to the right of the centre of the road, cross or straddle broken and unbroken lines, flat painted islands and flat dividing strips as long as it is safe to do so, and provided the driver has a clear view of approaching traffic.

## Being overtaken

If it is safe, move into the left lane to allow faster moving traffic to overtake.

It is illegal and dangerous to direct following vehicles to overtake, using your hand or the indicator. You may be encouraging an inexperienced driver to attempt an unsafe move.

## Lane changing

It is very important to check that the road is clear when you want to change lanes, or when lanes merge. You also need to check before leaving the kerb and before turning. You must look in the appropriate mirrors and do blind spot head checks before making any of these moves. In a heavy vehicle it is also essential to check down the side door in the cabin.

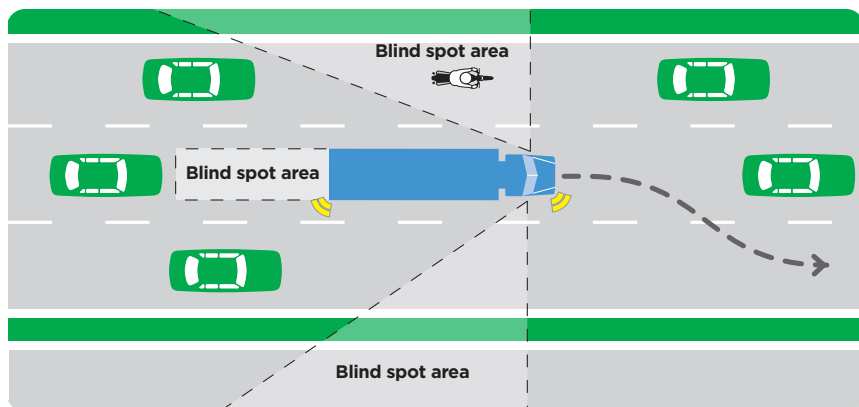

Before pulling out check mirrors, signal, check blind spot below cabin.

## Restricted areas for road trains and B-doubles

Road trains and B-doubles are Restricted Access Vehicles (RAV). These RAV vehicles may only travel on defined networks under authorisation or an exemption notice.

- Road train RAVs can operate as a National Class 2 Heavy Vehicle Road Train
- B-double RAVs can operate as a National Class 2 Heavy Vehicle B-Double

Information about Restricted Access Vehicle (RAV) maps and lists are available at [roads-waterways.transport.nsw.gov.au](https://roads-waterways.transport.nsw.gov.au)

If a road or route is not listed in the Notice apply to the National Heavy Vehicle Regulator for access.

This sign must be fitted to the back of vehicle combinations longer than 22m. B-doubles carry a greater payload than a single articulated vehicle and handle differently.

**LONG VEHICLE**

## Height and length limits

Heavy vehicle combinations are usually limited to a maximum overall length of 19m. B-doubles that meet specified conditions can travel at up to 26m in length. Other combinations such as road trains can operate in approved areas at greater lengths provided they meet specified conditions.

Generally heavy vehicles are limited to a maximum height of 4.3m. Travel at up to 4.6m high is permitted under various 4.6 Metre High Vehicle Notices listed online at [nhvr.gov.au](https://nhvr.gov.au)

Determining if a particular route is approved for 4.6m high vehicles, must be done by reference to the appropriate 4.6 Metre High Vehicle Notices (NSW and National) and the Restricted Access Vehicles (RAV) maps and lists.

The RAV maps are marked with the approved 4.6m routes.

Permits are also available to allow over-height vehicles, subject to any required route assessments and specific conditions, to travel on specified roads in NSW.

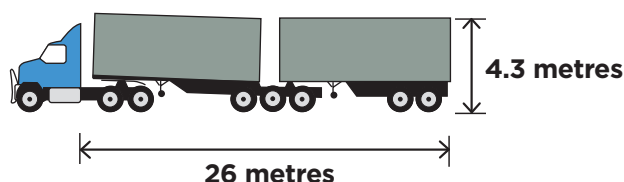



## Light traffic roads

You must not use any road with a load limit sign if the total weight of your vehicle is the same as, or heavier than, the weight shown on the sign.

You may use a light traffic road when that road is your destination for a pick-up or delivery and there is no alternative route.

## Load limit sign

You must not drive past a BRIDGE LOAD LIMIT (GROSS MASS) sign or GROSS LOAD LIMIT sign if the total of the gross mass (in tonnes) of your vehicle, and any vehicle connected to it, is more than the gross mass indicated in the sign.



## No truck sign

Drivers of long or heavy vehicles except buses must not drive past a NO TRUCK sign unless the vehicle is equal to or less than the mass or length specified on the sign.

When the sign does not provide detailed information, no truck (ie GVM greater than 4.5 tonnes) is permitted to drive past the sign, unless the drivers' destination lies beyond the sign and it is the only route.



## Trucks must enter sign

Heavy vehicle drivers must enter the area indicated by information on or with this sign.

## Where heavy vehicles can stand or park

Heavy vehicles (GVM of 4.5 tonnes or more) or long vehicles (7.5m long or longer) must not stop on a length of road outside a built up area, except on the shoulder of the road. In a built up area they must not stop on a length of road for longer than one hour (buses excepted).

## Warning triangles

A vehicle with a GVM of more than 12 tonnes must carry three portable warning triangles. These triangles must be used when the vehicle has stopped, broken down or its load has fallen on the road and cannot be seen (in all directions for at least 200-300m) by other road users.

When this occurs on a divided or one-way road, the driver must place:

- a warning triangle at the side of the vehicle or fallen load
- two warning triangles at the rear of the vehicle or fallen load.

When this occurs on any other road, drivers must place warning triangles at the:

- side of the vehicle or fallen load
- front of the vehicle or fallen load
- rear of the vehicle or fallen load.

Requirements for placing warning triangles on an undivided two-way road where the:

Speed limit is less than 80 km/h

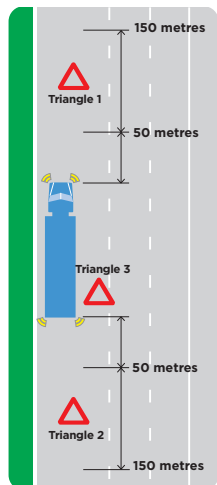

Speed limit is more than 80 km/h

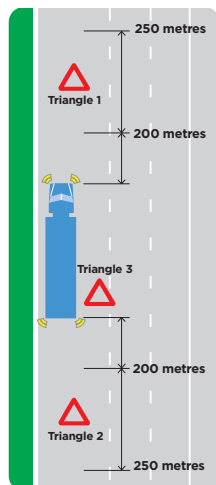

## Truck and bus lanes

### Truck lanes

Truck lanes are marked by the following sign. Trucks more than 4.5 tonnes GVM must use these lanes.





## Bus and bus only lanes

Bus and bus only lanes are marked by the following signs, or by lane markings. Public buses constructed principally to carry persons and equipped to seat more than eight adults, including the driver, and used to convey passengers for hire or reward, or in the course of trade or business, may use these lanes.



## Priority for buses

Other vehicle drivers should give way to a bus displaying the give way sign in a built-up area, when the bus is about to enter or proceed in the lane or line of traffic and the bus is in front of the driver.

You are still required to obey the road rules when entering the traffic.

Buses cannot park at bus stops but may wait at a bus stop prior to commencing a regular passenger service.

## Buses

### Stopping at a bus stop

Bus drivers should pull up so the entrance and exit doors are as close as possible to the kerb at a bus stop.

- signal your intention
- stop the bus smoothly
- stop parallel with the kerb
- stop within 300mm from the kerb measured from the front bus step
- stop the bus without hitting the kerb
- apply the bus stop brake. If the bus does not have a bus stop brake then you must apply the normal parking brake
- indicate for at least five seconds before pulling out of a bus stop.

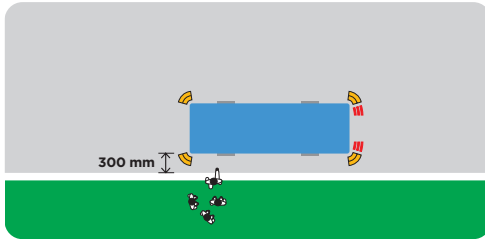

Stop within 300 mm of the kerb.

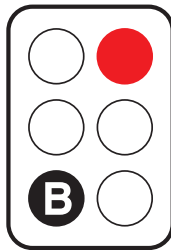

White B means buses only go.

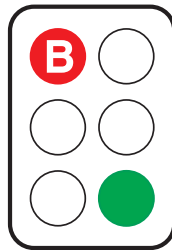

Red B means buses stay. Green means other vehicles go.

## Bus (B) signals

B signals separate buses and other vehicles at intersections with traffic lights. B signals are attached to the traffic lights and show a white B on a black background. Some traffic lights have a red, yellow and white signal attached. Shortly before the usual traffic signals change to green the B signal lights up white. Buses may proceed in any direction unless signs or markings indicate otherwise.

## Fires

To minimise the risk of fire:

- make regular checks of the vehicle during your trip
- follow recommended vehicle operating rules. See section 7 vehicle dimensions and loading
- check the instruments and mirrors as part of your regular scanning routine.

If there is a fire in your vehicle:

- Stop it well away from anything else which may burn
- Notify emergency services (call triple zero **000**)
- Use the correct fire extinguisher
- If the trailer is on fire, and it is safe to do so, uncouple the prime mover and move it away
- If the engine is on fire, try not to open the bonnet any more than necessary. Spray the fire extinguisher through louvres, or from the underside of the vehicle
- Where the load is on fire in a van or box trailer, open the doors slowly and only far enough to let you use the extinguisher properly.

## Vehicle monitors

---

Vehicle monitors are devices which automatically record details about the operation of a vehicle at all times, whether the engine is on or off. There are various types of vehicle monitors. Among them are tachographs and electronic boxes, also known as trip computers or black boxes.

Monitors record:

- lengths of time the vehicle is moving and stationary during a journey
- speeds at which the vehicle is driven
- distance the vehicle travels between stops
- the time, date and place of starting and finishing a journey, drivers' details and vehicle identification.

Monitors produce a continuous record of vehicle operation, allowing drivers and operators who break the law to be identified. Vehicle monitoring records also help identify vehicles on which the speed limiter has been tampered with or disabled.

### NSW registered vehicles which must have monitors

- Prime movers and articulated vehicles with a GVM or GCM of more than 13.9 tonnes and manufactured on or after 1 January 1991.
- All trucks with a GVM or GCM (if travelling in combination) of more than 13.9 tonnes carrying dangerous goods and required to display signs.
- All coaches used in the course of trade or business or for hire or reward.

Vehicle owners and transport operators are accountable if they schedule journeys that require drivers to exceed speed limits or driving hours.

## Vehicles not required by NSW law to have monitors

Vehicles being used within a radius of 100km from their usual depot unless carrying bulk dangerous goods. This includes:

- vehicles being driven for the purposes of original registration
- vehicles being driven for sale, provided no goods are carried in bulk quantity
- NSW primary producers' vehicles, provided evidence of the primary producer's concession registration is carried in the vehicle
- vehicles being driven under the direction of police or an authorised officer
- coaches used exclusively as route service buses on routes of less than 40km
- coaches used only as school buses
- vehicles registered federally or in other states or territories.

## Requirements for vehicles with monitors

### **Before you start the journey:**

- make sure the monitor is working properly
- record the time, date and place where the journey starts
- record the registration number of the vehicle (unless automatically recorded).

### **During the journey:**

- record the times the vehicle was driven and when it was stationary unless automatically recorded by the monitor
- record the name of each driver and times that each driver was in charge of the vehicle.

### **At the end of the journey:**

- record the date, time and place where the journey finished.

You may use the duplicate pages of the driver's work diary to record this information. If your monitoring device produces charts, attach the duplicate page to the chart. Alternatively, you can record the information on the back of the chart.

If your monitor breaks down during a trip, you must record, either on a chart or on a separate report:

- time
- date
- place
- type of break down.

You must continue to record the items referred to in this section and the distance travelled.

If you own a vehicle, you must ensure that:

- your vehicle monitor is working correctly, is properly calibrated and that its seals are intact
- your vehicle specifications are not altered in any way that could affect calibration of the device
- your device is recalibrated immediately when the vehicle specifications are altered or at least every six years
- your drivers are instructed properly in the use of the device
- you recover trip records from your vehicle and store them in continuous date order for at least six months
- you make your records available at the request of an authorised officer
- you check the records for each trip and for each driver to ensure that driving hours and speed limits have been observed
- your drivers continue to keep manual records for each journey if the monitor breaks down.

## Police checks and Transport for NSW inspections

The police can check that your vehicle monitor is fitted and working properly. If you are ever involved in a serious crash, or if there is suspicion of serious offences, police may need your monitor and data.

Transport for NSW inspectors can make monitor checks for vehicle operators and companies by:

- visiting vehicle depots
- reviewing mailed records
- conducting audits.

# Knowing the vehicle

Heavy vehicles come in a variety of configurations. It's your responsibility to know your vehicle. Regular checks and services are required by law, to minimise the risk of breakdown and ensure your vehicle is roadworthy.

## Roadworthiness

---

The driver and the owner/operator are responsible for a vehicle's roadworthiness. A roadworthy vehicle is a safe one that offers advantages to both driver and operator as well as other road users. Unroadworthy vehicles can be heavily fined, especially if they are involved in a crash.

It is very important to check your vehicle is roadworthy. Pre-departure checks can save time and expense later on and reduce the chance of a crash resulting from mechanical failure.

To make sure that your vehicle remains roadworthy, you should carry out daily pre-departure checks and more 'in depth' weekly inspections. Refer to the checklists in this section as a guide.

## Body/cab condition

---

All door latches or hinges must be secure and working well. The cabin must be sealed from engine and fuel areas.

## Brakes

---

### Air brake operation

Most heavy vehicles have full air brakes. It is important that brakes are properly adjusted and well maintained.

When you apply the foot brake pedal you are opening a valve that allows pressurised air to flow to the brake chambers at each wheel. Therefore braking effectiveness depends on how far you depress the pedal, unlike a car where the braking effectiveness depends on how hard you depress the pedal.

It is very important to check your brakes properly and regularly, and to refer to the manufacturer's manual. Use the following procedure as a guide only and get a professional to service your brakes often.

## Inspection of hydraulic brakes

### STEP 1: External check

1. Check for line damage and leaks.
2. Check wheel backing plates and brake hoses for any signs of leaks or damage, such as chafed hoses or pipes
3. Check around the master cylinder and hydraulic oil reservoir for leaks. Also check that the reservoir is full.

### STEP 2: System check

1. Check the feel of the brake pedal when you apply the foot brake. If the pedal sinks down further than usual or if it feels spongy, there may be a leak or air in the system.
2. Keep full pressure on the pedal – it should continue to be hard. If the pedal starts to sink, there may be a leak in the system.
3. Vacuum brakes – check booster retention with full vacuum and the engine off. When you apply the pedal it should stay down without resistance. The vacuum must be available soon after the engine is started with low vacuum available after 30 seconds and normal working vacuum after 60 seconds.
4. Check that the vehicle does not pull to one side when you brake with the vehicle moving, off road if possible.

## Inspection of air brakes

### STEP 1: Secure the vehicle

1. Put on the parking brake.
2. Switch off the engine.
3. Where manual valves are fitted to air tanks, drain daily.

It is illegal to discharge fluid on the ground as it can be washed down drains and is an environmental hazard.

### STEP 2: Drain all air tanks

On vehicles with a dual circuit braking system, drain one system first. Check to make sure that only one gauge indicates no pressure, then drain the other system. If both gauges show no pressure after draining one system, do not use the vehicle before your brakes have been checked by a professional.

### STEP 3: Refill the system

1. Start engine and run at fast idle – do not race the engine.
2. Check that:
  - any low air pressure warning signals (if fitted) are operating as a result of having no air in the system
  - the low air pressure warning signals (if fitted) operate at about 410kPa
  - the time it takes for air pressure to build up from 0 to 80 per cent of maximum pressure limit (refer to manufacturer's specification) is not longer than five minutes.
3. Allow maximum pressure to build up and turn off engine.

### STEP 4: System check

1. Chock the wheels and release the park brake.
2. Apply the foot brake fully and check the drop in air pressure on the gauge. The drop in pressure per minute should not exceed the following:
  - truck 20kPa
  - truck and trailer 30kPa.



3. Apply the foot brake another four times, holding it down on the fourth application. The pressure should not have fallen by more than half normal system operating pressure.

If it has, do not use the vehicle before your brake system has been checked by a professional.

4. Recharge air system.

#### **STEP 5: Trailer check**

1. Turn the engine off.
2. Disconnect the air hoses between the hauling unit and trailer (articulated vehicles and truck/trailer combinations). The trailer brakes must automatically come on and remain on for at least 15 minutes. This is to check if the breakaway system is operational.
3. Check the tractor protection system of the hauling unit after air has stopped being released from the hauling unit trailer air line fittings. If these fittings contain self-sealing devices, hold them open until no more air is released.
4. Check that the:
  - air pressure is in excess of 300kPa
  - service brakes still work
  - spring brakes (if fitted) have not come on.

#### **STEP 6: External check**

1. Re-connect air hoses.
2. Apply the park brake.
3. Walk around the vehicle and listen carefully for air leaks.

#### **STEP 7: Final check**

1. Start the engine to recharge the air system.
2. Release and re-apply the park brake and walk around the vehicle again and listen carefully for air leaks.

These 'general checks' do not replace the need for thorough inspections of the systems.

## Anti-lock Braking Systems (ABS)

Many trucks have ABS, which is designed to stop wheel lock-up and improve steering under heavy braking.

Maximum braking occurs when the wheels are just on the point of locking. However, if a wheel does lock and skidding occurs, braking is not effective and you may lose control of the vehicle.

For best results when using an ABS-equipped vehicle in an emergency situation, press the brake pedal down fully and allow the ABS to regulate braking for you. This allows you to have full steering control at the same time as maximum braking.

If the ABS fails, the system reverts to normal brake operation.

## Parking brake

When applied a parking brake must be capable of holding the vehicle stationary on any slope up to a gradient of at least 15 degrees, or prevent it from moving under light throttle and must function by mechanical means such as springs.

## Engine/exhaust brakes or speed retarders

These devices may be fitted to medium and large vehicles to supplement the vehicle's service brake system. They will not stop the vehicle completely but may help to slow it down. They are not considered service brakes as they act on the engine or drive train.

Three most common types are:

- exhaust brake
- engine brake
- electric, magnetic or hydraulic retarder.

Applying these brakes may cause a lightly loaded vehicle to skid or jack-knife on slippery roads.

Auxiliary brakes are generally noisier than the service brake. Try to reduce brake noise in urban areas by limiting the use of Auxiliary brakes.

## Couplings

---

**Prime mover/semi-trailers** – Turntable mountings and other tow couplings must be secure and comply with Australian Standards for installation.

**Other vehicles** – All towbar, coupling and drawbar components must be in good working condition. Steps on performing uncoupling and coupling are covered at the end of this section.

## Driving controls

---

All controls should function correctly and be regularly checked and maintained.

## Electrical system

---

Electrical wiring and connections, both inside and outside the vehicle, must be secure, damage-free and not exposed to excessive heat.

## Engine

---

When running above idle speed, the engine must not discharge excessive crankcase fumes. See Smoke from engines in section 8.

## Exhaust system

---

The exhaust system must not have leaks due to damage, looseness or poor maintenance.

The exhaust system must not be too noisy. See Noise pollution in section 8.

## Fuel system

---

The fuel tank and lines must be secure and not leak. The fuel tank cap must be properly fitted.

LPG fuelled vehicles must be fitted with an AUTOGAS plate near the LPG fuel tank and display the appropriate plates or stickers on the front and rear number plates.

Compressed Natural Gas (CNG) is an alternative fuel commonly used in NSW in buses. A CNG vehicle must display the appropriate plates or stickers, be fitted with a compliance plate and also be fitted with a refuelling information plate near the filler connection. Ensure CNG cylinders are periodically inspected.



CNG retro reflective identification labels must be circular with a diameter of at least 35mm and have CNG in capitals at least 10mm high.

LPG retro reflective identification labels must be at least 25mm high, 25mm wide and have LPG in capitals at least 10mm high.

**LIQUEFIED PETROLEUM GAS COMPLIANCE PLATE**

The autogas installation to which this notice is affixed complies with the requirements of Australian/New Zealand Standard AS/NZS 1425

INSTALLATION DATE ..... STATE .....

COMPLIANCE No .....

INSTALLED BY:

NAME ..... LIC. No .....

WORKSHOP No ..... (REP. No)

VIN No .....

CONTAINER SERIAL No .....

CONTAINER TEST STATION STAMP DATE .....

Example of a LPG Compliance plate.



## Gear boxes

Heavy vehicles greater than 4.5 tonnes GVM must use low gear on roads where a sign displays TRUCKS & BUSES MUST USE LOW GEAR. The gear chosen by the driver must be able to control the speed of the vehicle without use of the brakes.

There are three types of gear boxes.

### Non-synchromesh gear box (constant mesh)

In this type of gear box, the matching of engine and road speeds depends entirely on your judgement and skill as there are no synchronisers in the gear box to help you. Double-declutching is essential while you are learning to use this type of gear box. A non-synchromesh gear box may commonly be known as a crash or constant mesh gear box.

## Synchromesh gear box

This type of gear box works in much the same manner as those in most modern cars. They are easy to use, as the synchronising of the gears is done by the gear box. Be aware that damage can be caused by forcing gear changes before the engine and road speeds are matched.

## Automatic gear box

These work in much the same manner as in modern automatic cars.

## Double-declutching

Double-declutching means to change gear, by moving the gear lever first into neutral and then into the desired gear, releasing the clutch pedal between each movement. You should learn this technique from someone who is experienced with the practice.

Double-declutching is not recommended for synchromesh gear boxes as it may cause long term damage.

## Lights and indicators

---

All lights and reflectors must work properly and their lenses must not be damaged. All rearward facing lights except reversing and indicator lights must be red.

### Warning lights

Parking brake and brake failure warning lights, where fitted, must work.

### Flashing lights

Flashing warning lights must be visible in normal daylight from a distance of 200m to drivers approaching from any direction. A flashing light can be distracting to the driver so must not be directly visible from the normal driving position of the vehicle to which it is fitted.

A flashing light displayed on a vehicle may only be amber/yellow, blue green or magenta/crimson. Each of these colours or combination of colours is intended to convey a specific warning to road users. Their use is limited to particular types of vehicles and in particular circumstances.

An amber/yellow flashing light warns road users of an obstruction to the free flow of traffic and can be used by public utility vehicles, tow trucks, motor breakdown service trucks and street vending vans.

Blue or blue and red flashing lights may only be fitted to police vehicles, ambulances, operational fire brigade and accredited bush fire brigade vehicles or a vehicle used by a traffic commander or a traffic emergency patroller appointed or employed by Transport for NSW.

A red flashing light warns road users of the presence of an emergency service vehicle associated with a risk-to-life situation. They may only be fitted to ambulances, operational fire brigade and accredited bush fire brigade, mine rescue vehicles, State Rescue Board (SRB) accredited rescue vehicles, State Emergency Services (SES) vehicles and Red Cross vehicles for urgent blood deliveries.

A green flashing light warns road users of the presence of a stationary operational fire brigade, accredited bush fire brigade, ambulance or police emergency site command vehicle. Green flashing lights may not be fitted to any other type of vehicle and should not be operated on an approved vehicle while it is in motion.

A magenta/crimson flashing light warns road users of the presence of a Transport for NSW enforcement vehicle or a vehicle driven by a local council officer while engaged in monitoring or measuring the weight of heavy vehicles.



## Rear marking plates

All motor vehicles with a GVM exceeding 12 tonnes and trailers with a GTM over 10 tonnes must be fitted with retroreflective marking plates at the rear of the vehicle. Smaller trucks may have rear marking plates fitted too.

Prime mover and semi-trailer combinations must display rear marking plates at the rear of the semi-trailer.



Rear marking plates may also display DO NOT OVERTAKE TURNING VEHICLE in black letters 50mm high as shown if the vehicle exceeds 7.5m in length. See section 5 Heavy vehicle road rules for details. Only use plates with approved retroreflective material. Do not modify or use alternative plates except those described previously.

Keep the plates clean and in good condition. Plates must not be covered or obscured by any vehicle equipment or load.

When a hauling unit vehicle is rated with a GCM exceeding 12 tonnes or the sum of the laden mass of the trailer and hauling unit exceeds 12 tonnes, rear marking plates must be fitted to the rearmost trailer being towed.

Rear marking plate rules do not apply to route buses used only in urban areas.

The marking plate shown below may be an acceptable alternative, if the first option is not practicable, provided it meets specific dimensions and locations. For further information refer to Vehicle Standards Information No:13 - Rear Marking Plates for Heavy Vehicles.



Typical fitting of alternative style class 2 plate (type 1).

## Rust and corrosion

Any structure, chassis, frame etc must not have advanced rust. Any panel separating the driver or passenger from fuel or engine fumes must not have advanced rust - that is rust which would cause the metal to collapse in a crash.

## Seats and seatbelts

---

Seat frames or mountings must be structurally sound with all seatbelts undamaged and working properly.

## Steering

---

The steering wheel must be undamaged and firmly attached to the steering column. All steering components must be secure, undamaged and not have excessive free play.

## Structure

---

Any structure, chassis, frame etc must not be distorted, cracked or damaged.

## Suspension

---

Suspension springs must not sag or be modified and all suspension components must be aligned and undamaged.

## Wheels and tyres

---

All wheels must be properly attached to the vehicle with the right number and type of nuts and studs and wheel rims must not be cracked or bent.

All tyres must have at least 1.5mm tread depth over 75 per cent of tyre surfaces which normally contact the road. All tyres must have correct air pressure. Manufacturer's recommendations are a good guide.

Regrooved tyres are acceptable provided such tyres (or retreads) are marked by their manufacturers as being suitable for regrooving. This only applies to heavy vehicles. Regrooved tyres must be retreaded to meet the requirements of an appropriate version of Australian Standards AS 1973.

## Windscreen and windows

---

The windscreen directly in front of the driver or in the path of the windscreen wipers must not be cracked, scored or chipped.

Wiper blades, windscreen washers and demisters must be fitted and work well.



## Pre-departure checks

All drivers are legally responsible for the safety and roadworthiness of the vehicles they drive. Before driving any vehicle you must ensure it is safe and roadworthy.

### Pre-departure safety checks

It is very important to check your vehicle before you drive, particularly items that have been reported defective. These checks can save time and expense later on, reducing the chance of component failure and subsequent loss of vehicle control, which may result in a crash.

These inspections should be conducted prior to shift start (no matter what the time of day) and always following the manufacturer's recommendations. The areas you need to cover are listed in this section.

#### Engine compartment

- |                            |                          |
|----------------------------|--------------------------|
| Engine oil level           | <input type="checkbox"/> |
| Engine coolant level       | <input type="checkbox"/> |
| Clutch fluid level         | <input type="checkbox"/> |
| Brake fluid level          | <input type="checkbox"/> |
| Power steering fluid level | <input type="checkbox"/> |
| Screen washer fluid level  | <input type="checkbox"/> |
| Ancillary drive belts      | <input type="checkbox"/> |

#### Electrical

- |                               |                          |
|-------------------------------|--------------------------|
| Headlights: high and low beam | <input type="checkbox"/> |
| Driving and fog lights        | <input type="checkbox"/> |
| Park lights                   | <input type="checkbox"/> |
| Indicators: left and right    | <input type="checkbox"/> |
| Clearance lights              | <input type="checkbox"/> |
| Tail lights and plate light   | <input type="checkbox"/> |
| Brake lights                  | <input type="checkbox"/> |
| Hazard lights                 | <input type="checkbox"/> |
| School warning lights         | <input type="checkbox"/> |

Continued over the page

## Vehicle posture, leaks and load

---

- Vehicle posture
- Fluid leaks
- Load properly secured (trucks)

## Coupling

---

- Air hoses and cables
- Security

## Vehicle body

---

- Body damage
- Mud flap(s) and guards - front and rear
- Cabin entry grab handles
- Door operation and locks
- Windows - operation and damage
- Bus rear window - Emergency Exit
- Cargo and luggage doors (if available)
- Mirror(s) - lens and security
- Plates and signs
- Fuel tanks
- Air tanks
- Toolbox(es)
- Other

## Brakes

---

- Foot and hand controls correctly adjusted and not worn
- Hydraulic brakes
- Brake fluid reservoirs must be full
- Hoses, pipes and cylinders leak free
- Rigid pipes bracketed, free of rust and have grommets when passing through chassis frames
- Air brakes
- Compressors, drive belts, exhausters and reservoirs securely mounted and undamaged
- Brake air lines, hoses, valve drain cocks and plugs secure, functional and leak-free

## Wheels and tyres

---

- Rims (dents in flanges, loose lugs and nuts, rust trails, cracks in rim assembly)
- Tyres (tread minimum legal depth of 1.5mm)
- Tyre inflation correct
- Tyre cuts, damage, dual tyres touching, rocks lodged between duals
- Spare wheel(s)/tyre(s)

## Generally

---

- Registration label(s) current and attached
- Windscreen wipers
- Warning triangles
- Fire extinguishers
- Other

## Dealing with problems

---

If the vehicle you are driving has a maintenance or mechanical problem, you must make a written report on a form supplied by the owner.

Keep a record of all repairs and check that the fault has been fixed. Take it back to the repairer if the problem persists.

## Defect reporting

---

If the vehicle you are driving has a maintenance or mechanical problem, inform the owner of all symptoms in a written report.

# Uncoupling and coupling

Uncoupling and coupling a prime mover and semitrailer is a task which can lead to serious accidents, injury and vehicle damage. Follow these steps to perform the task correctly.

## Uncoupling a semi-trailer

---

### STEP 1: Secure the vehicle

1. Before uncoupling:
  - Make sure your semi-trailer is parked on a level area.
  - Ensure the vehicle is on a surface firm enough to support the trailer landing gear and its load.
  - Make sure the prime mover and semi-trailer are in a straight line.
2. You will then need to:
  - Apply the parking brakes and tractor/trailer protection valve.
  - Ensure trailer security by giving it a ‘tug test’ with the prime mover to see if the trailer moves or by chocking the trailer wheels.
  - Always use chocks when you have to park a semi-trailer on a grade. It is best to chock the semi-trailer’s front axle in case the landing legs collapse and the rear axle(s) lifts.
  - When you uncouple on soft ground, put suitably strong timber or other flat supports under the landing gear.

Large pressure drops during a static brake check may indicate that there is a problem. Always have this checked.

### STEP 2: Trailer check

1. Lower the landing gear ensuring firm and even contact with the ground.
2. Raise the trailer until a gap is visible at the fifth wheel (turntable).
3. Secure the landing gear handle.

**STEP 3: Uncoupling the trailer**

1. Release the turntable jaws. If the release handle cannot be moved, the jaws may be under load.
2. Take the pressure off by gently rocking the prime mover forward and back and then try to release again.
3. Move forward slowly. Release the prime mover parking brake and slowly drive forward in a straight line until the fifth wheel is just clear of the trailer skid plate, making sure the trailer stays put, using the trailer brakes if necessary.
4. Apply prime mover park brake.

**STEP 4: Final check**

1. Disconnect the air hoses and electrical cables from the trailer.
2. Stow hoses and cables properly on the prime mover making sure that the connectors are kept free of dust and water, and that they cannot get caught on the tail shaft.
3. Drive away slowly. Ensure the driver's door is closed whenever the vehicle is moving.

## Coupling a semi-trailer

---

### STEP 1: Position the vehicle

1. Reverse the prime mover into position, lined up straight in front of the trailer, stopping the prime mover with the skid plate just touching the trailer.
2. Apply the parking brake.

### STEP 2: Trailer check

1. Check the trailer skid plate, kingpin, turntable jaws, airlines, leads and connections for damage.
2. Make sure the turntable jaws are open.

If the trailer:

- Has a block welded to the skid plate about 30 cm behind the kingpin, make sure the top of the turntable is the type which turns and is unlocked.
- Is without the block the turntable will need to be locked in position. Make sure the top of the turntable is well greased when it is used in the locked position.

### STEP 3: Secure the trailer

1. Ensure trailer is secure. Place chocks behind at least one wheel. If the trailer is equipped with spring brakes, the trailer brakes should already be on.
2. Check that the turntable and kingpin are lined up and that the prime mover will clear the trailer.
3. Check and adjust the height of the skid plate to the turntable. The height of the trailer skid plate should be slightly lower than the centre of the turntable. About five centimetres is ideal.
  - If the trailer is too low, the prime mover chassis or edge of the turntable can hit the trailer front instead of going under.
  - On a trailer that is too high, the turntable may not latch on to the kingpin, or the turntable could even pass beneath the kingpin, allowing the prime mover cab to hit the trailer.

### STEP 4: Trailer check

1. Connect air hoses and electrical cables (do not forget to twist lock ring on bayonet fittings).
2. Set tractor protection valve (if fitted) to normal.
3. Apply the trailer brake.
4. Check brake air pressure.

**STEP 5: Coupling the trailer**

1. Reverse the prime mover slowly under the trailer until the turntable jaws lock around the kingpin.  
You should hear the jaws close and lock into place.
2. Raise landing gear just clear of the ground.
3. Perform a 'tug test' to check the trailer is locked on by trying to move off in first gear with the trailer brakes on.  
The prime mover should not move.
4. Repeat this check to be absolutely sure.
5. Check that the coupling release lever is in the locked position and there is no gap between the turntable and the trailer skid plate.  
A visible gap between the turntable and the trailer skid plate may mean the trailer is set too high.  
Try lowering the trailer on the landing gear slightly and the gap should close but if it does not check for any problems.
6. Check that the turntable jaws are closed correctly and have locked on to the kingpin.  
Make sure that the head of the pin is not sitting on top of the jaws.
7. Fully raise the landing gear and stow the handle.  
Check that there is enough clearance for normal movement between the prime mover (frame and wheels) and the trailer frame.  
Check also that there is enough clearance between the landing gear and the back of the truck frame to allow for turning.

**STEP 6: Final check**

1. Run the engine until the air pressure has reached its maximum in the air tanks.
2. Switch off the engine, apply the parking brakes, and turn on the hazard warning lights, side and tail lights.
3. Perform an inspection by walking around the truck and trailer listening for air leaks, and checking all trailer lights are operational.
4. Remove and stow wheel chocks.
5. Allow time for air ride systems to prime before moving off as substantial damage may occur if not in the full ride position - this may take time with some combinations eg B-double.

## Uncoupling a truck and trailer

---

### **STEP 1: Secure the vehicle**

1. Before uncoupling:
  - make sure your truck and trailer are parked on a level area
  - ensure they are on a surface firm enough to support the trailer drawbar support leg if fitted
  - make sure the truck and trailer are in a straight line.

### **STEP 2: Trailer check**

1. Apply park brake and truck/trailer protection valve.
2. Ensure trailer security by 'tug test' or chocking wheels.

### **STEP 3: Uncoupling the trailer**

1. Lower drawbar support leg.
2. Disconnect and secure all hoses and cables.
3. Release towing connection.
4. Drive slowly forward.
5. Check mirrors to confirm disconnection.



## Coupling a truck and trailer

---

These procedures may need to be varied.

### **STEP 1: External check according to actual vehicle configuration and manufacturer's recommendations**

1. Check coupling assembly including guide flange, towing and locking pins, and connections.
2. Check pin is in the coupling position.

### **STEP 2: Secure the trailer**

1. Placing chocks behind at least one wheel or if the trailer is equipped with spring brakes, the trailer brakes should already be on.

### **STEP 3: Coupling the trailer**

1. Reverse truck close to, but not touching, draw bar.
2. Check height and alignment of eye ring to coupling assembly, adjusting if necessary.
3. Reverse truck slowly until the towing system is locked or in position to be connected.
4. Perform a 'tug test'.
5. Look to check the connection.
6. Connect air hoses and cables.
7. Raise drawbar support leg and stow (if fitted).

### **STEP 4: Final checks**

1. Check brake air pressure.
2. Switch off engine and inspect by listening for airleaks, stowing chocks and checking all trailer lights are operational.
3. Remove and stow wheel chocks.

# Vehicle dimensions and loading

It is the responsibility of the driver to ensure the vehicle does not exceed dimension or mass limits and that the load is appropriately restrained.

## Load shift

---

When moving, a vehicle's load can shift from forces caused by changes of speed, braking, accelerating, cornering, travelling over uneven road surfaces, and slopes. Load shift needs to be managed to prevent danger to any person or damage to any property.

### How to carry a load safely

To carry a load safely and prevent danger to any person, or damage any property you must:

- choose a suitable vehicle
- position the load correctly
- use suitable and adequate restraint equipment
- use appropriate driving methods.

## Vehicle dimensions

---

### Maximum heights

- Double deck bus 4.4m.
- All other vehicles 4.3m.

Certain types of commercial vehicles, and vehicles carrying specified commodities, may operate to a maximum 4.6m high. These vehicles are only permitted on specified routes and are subject to conditions contained in the National Class 2 Heavy Vehicle 4.6m High and/or 25m long Vehicle Carrier Authorisation (notice) 2014 or National Class 2 4.6m Livestock Carrier Authorisation (Notice) 2014 available at [nhvr.gov.au](http://nhvr.gov.au)

## Maximum widths

The maximum width limit for all vehicles is 2.5m. When you measure the width do not include external rear vision mirrors, signalling devices and tyre pressure monitors.

For more information on maximum axle loads, including maximum allowable axle weights with 'super single' (wide profile) tyres, get the fact sheet, National Heavy Vehicle Mass and Dimensions Limits from [nhvr.gov.au](http://nhvr.gov.au)

## The right vehicle

To carry a load safely you must make sure the size of the load space and the condition of the platform are suitable for the job you want to do.

Vehicles carrying:

- long loads should be long enough to avoid excessive overhang and ensure good weight distribution for vehicle stability
- liquids and loose bulk material must be designed to completely contain the load and to minimise the effect of load movement.

To carry a load safely you must make sure the size of the load space and the condition of the platform are suitable for the job you want to do.

If your heavy vehicle and/or load exceed the requirements of the relevant Notice an access permit will be required. Contact the National Heavy Vehicle Regulator on 1300MYNHVR (**1300 696 487**) or email [info@nhvr.gov.au](mailto:info@nhvr.gov.au)

## Contained loads

---

Tipper bodies are best to contain loose loads such as bush rock, sand, gravel etc. The most suitable vehicles for these loads have solid sides and tailgates such as tippers. The solid sides prevent the load from spilling. Sheets or tarpaulins should be used to cover loose loads to prevent them from being blown out of the truck. Liquid loads or 'fine powder loads' such as cement powder, flour etc are best contained in tankers.

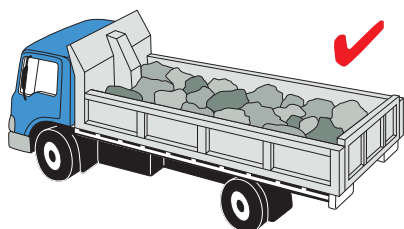

A correctly contained loose load.

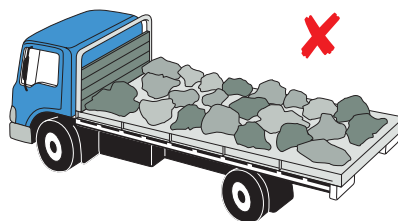

Loose loads need to be safely restrained as shown on the left.

## Heavy loads

---

A long, heavy load can also make your vehicle difficult to handle. You can overcome this by using the right vehicle for the job.

An incorrectly loaded heavy load can take weight from the front wheels and make steering difficult. On rough roads, the truck may pivot on its rear wheels, lifting the front wheels entirely off the road.

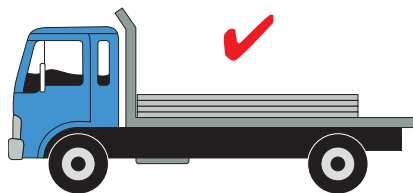

The load weight is positioned and evenly distributed.

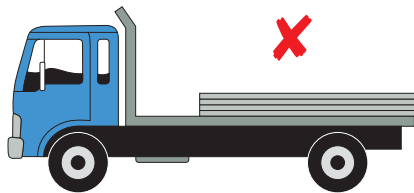

The load is dangerously positioned.

## High loads

These are loads with a high centre of gravity. It may even tip over when cornering. High loads should be carried on vehicles with a low platform whenever possible such as a drop frame trailer or low loader.

The overall height of a loaded vehicle must be checked to make sure that it clears any overhead bridge or other obstruction on your route. It must not exceed 4.3m in height unless you have a special permit.

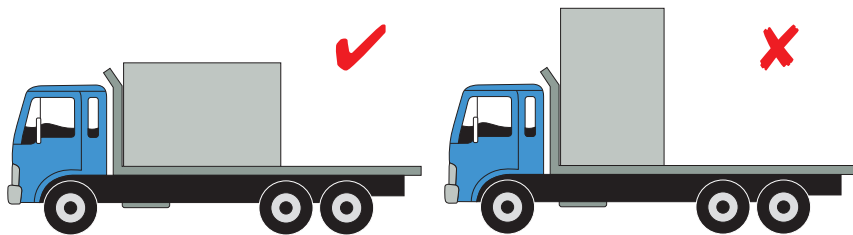

The load weight is well positioned and evenly distributed.

The load is dangerously positioned with the centre of gravity too high.

## Tankers

Bulk liquid loads should be carried in tankers and have the same problems of weight distribution as other loads as well as the special problems of a fluid load.

Avoid swerving and slow down before any curve or corner.

The tank is divided into compartments which are filled separately. Be aware that difficulties can be caused by the partial filling of compartments. A part-filled compartment allows the liquid to move from side to side (cornering) and rear to front (braking). The shift of the cargo's centre of gravity is a safety concern because it makes the vehicle easier to rollover. Try to empty one compartment completely before you start to empty another one.

Always empty the centre compartments first and work outwards to keep weight evenly balanced over the front and rear axles of the vehicle.

There is still some space left when the compartment registers full – this reduces spillage and allows for expansion of the fluid.

This small space also allows the fluid to move but much less than if the compartment has been partly emptied. Even minor movements are sometimes enough to make your vehicle unstable and perhaps cause a rollover.

## Clearance signs and low clearance signs

You should ensure that you know the total height of your vehicle and its load before driving it on a road. You must also obey clearance signs and low clearance signs that impose restrictions on the height of vehicles that can travel near, under or through an asset.

You should also ensure that prior to any journey you plan your trip to identify any restrictions that may affect your proposed route.

If your vehicle exceeds 4.3m in height you must either ensure that the vehicle meets the requirements for travel under one of the 4.6m High Vehicle Notices or obtain a permit.

You must always obey clearance and low clearance signs.

Penalties for ignoring clearance signs have been increased and include fines and loss of points. In some cases the registration (or visiting vehicle privileges) of vehicle units involved in a breach can be suspended for up to 3 months.

## Loading

Restrictions on the mass and loading of vehicles and vehicle combinations have been set by the Heavy Vehicle (Mass, Dimension and Loading) National Regulation and apply to any vehicle with a GVM of more than 4.5 tonnes or any vehicle combination with a GCM of more than 4.5 tonnes.

The limits on the mass or weight of your vehicle (including the load) are set to reduce wear on roads and bridges, and to increase safety. Vehicle manufacturers set gross mass (GVM/GCM) limits for each vehicle model.

A vehicle must not be operated at a mass limit that will exceed the:

- manufacturer's GVM/GCM
- manufacturer's individual component rating (ie axles, springs, tyres etc)
- statutory mass limits or overall axle spacings.

It is the operator's responsibility to make sure these limits are not exceeded.

Part of your vehicle registration fee covers the cost of road wear and maintenance. National charges are calculated using the vehicle type, the GVM on the compliance plate, number of axles and the nominated configuration (usage) of the vehicle (the penalty for overloading a vehicle may exceed \$2200 for an individual and \$11,000 for a corporation).

### The cost of overloading

Millions of dollars are spent every year to repair damaged roads and bridges. This is not covered by registration fees or overloading fines as they only recover a small part of this cost.

Even a little overloading causes a lot of damage to roads and bridges, which everyone must pay for. It is very important for the future of NSW roads and the heavy vehicle industry that you do not overload your vehicle.

## Projecting loads

This information applies to vehicles with a GVM over 4.5 tonnes. For details regarding projecting loads for vehicles with a GVM of 4.5 tonnes or less, refer to the Road User Handbook.

A load on a vehicle must not project more than 1.2m in front of the vehicle, or more than 150mm from the side of a vehicle. The vehicle width, including the load, must not be greater than 2.5m.

A warning signal must be attached to the rear of the load in daytime if it:

- projects more than 1.2m behind the vehicle
- overhangs the rear of the vehicle so that the end of the load cannot be seen easily from behind
- is on a pole type trailer.

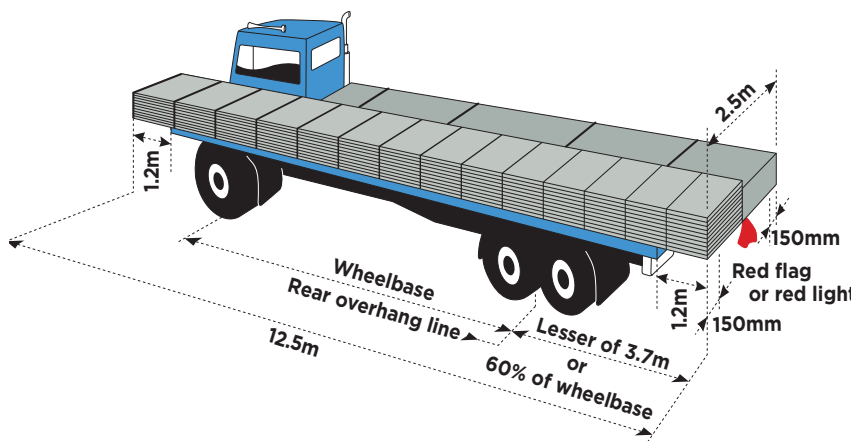

This diagram shows the allowable projected load limits.

The warning signal must be a brightly coloured flag or piece of material with each side at least 300mm long. At night-time the warning signal must be a red light which can be seen for 200m.

A load on a vehicle must not project in a way that is dangerous to any person or likely to cause property damage, even if all dimension and warning requirements are met.



For vehicles over 4.5 tonnes GVM, the rear overhang, including the load, must not exceed 60 per cent of the vehicle's wheelbase or 3.7m, whichever is less.

If the size of the vehicle, or vehicle with load, is more than the allowable length, you must get a permit from the National Heavy Vehicle Regulator. The maximum allowable length for a rigid vehicle, including any overhanging load front or rear, is 12.5m. The maximum allowable length for an articulated or heavy trailer combination vehicle, including any overhanging load, is 19m.

## Dangerous projections

A load with any potentially dangerous projection should be placed to minimise risk to the driver or any other person, should the load shift during braking or a collision.

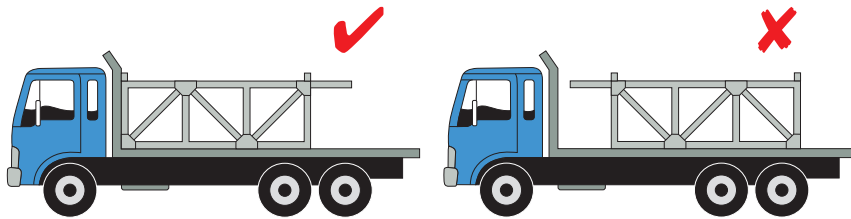

The potentially dangerous projection is correctly positioned to minimise the risk of load shift.

The load is incorrectly positioned and projections are potentially dangerous in the event of load shift.

Security of the load on trucks must meet performance standards as set out in the Load Restraint Guide available from [ntc.gov.au](http://ntc.gov.au)

## Load distribution and arrangement

An overloaded vehicle is unsafe to drive, inefficient to operate and damages the road.

Poor load distribution can cause:

- loss of steering
- loss of traction under power
- wheel lock-up under braking resulting in a jackknife or trailer swing
- vehicle roll-over on a roundabout or when changing lanes.

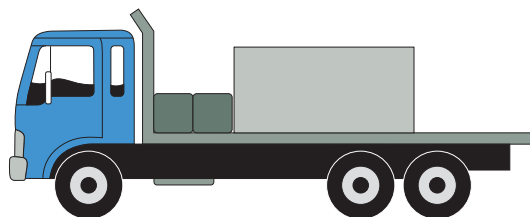

The weight of the load should be evenly distributed.

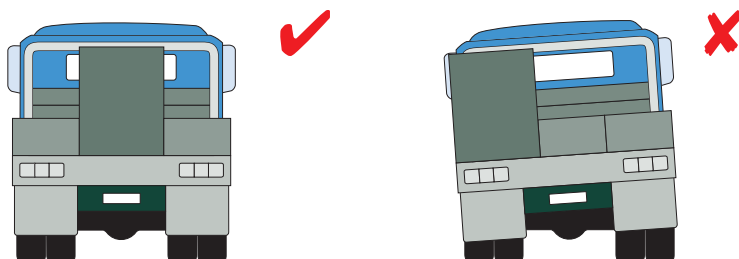

The weight of the load needs to be evenly distributed.

It is very important to have even distribution of maximum permitted weight because:

- maximum permitted axle loads will not be exceeded
- driving control is improved through the wheels
- the chassis frame will not be damaged by twisting or bending.

## Positioning the load

---

For stability, the load should be spread close to the centre line of the vehicle. You should stack the heavier things at the bottom. Loading a heavy item on one side may result in twisting and stress on the chassis frame, or overloading of axle housings, wheel bearings and tyres. This could be bad enough to:

- allow the brakes to lock on the wheels on the lighter side
- cause flat spots on the tyres
- skid on a wet surface.

Problems may occur in a rigid vehicle, when a very heavy small load is placed against the headboard. This could cause:

- the chassis frame to bend, perhaps permanently
- overloading in the front tyres
- irregular tyre wear or even a blowout.

Avoid these problems by placing any small heavy load just ahead of the rear axle.

If you need to place a load back from the headboard to distribute weight, the load should be blocked so that it cannot move forward. Unless it is blocked, even the heaviest load will move forward if you stop suddenly.

## Securing the load

---

The following information is a guide only. Detailed information on securing your load is available in the Load Restraint Guide.

The way your vehicle is loaded is very important for your safety and for the safety of others. You are legally responsible for your load and any damage or injury it may cause.

Driving over bumps in the road, around curves and corners, and accelerating and braking can cause your load to move. The force of an impact can move a load that is unstable or not properly secured and you can lose control of your vehicle.

The weight of your load should also be evenly distributed so you can control your vehicle properly.

## Load restraints

A load restraint system on a vehicle should be capable of restraining the following percentages of the weight of the load from shifting:

- 20 per cent upward
- 80 per cent forward
- 50 per cent rearward
- 50 per cent sideways.

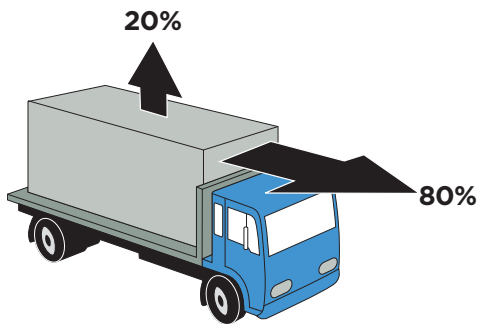

20% upwards and 80% forward.

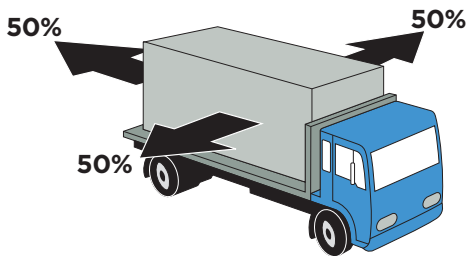

50% rearward and sideways.

Loads must be secured to prevent:

- any part of the load hanging over or sticking out of the vehicle in a way which could hurt someone, damage property or cause a hazard to other road users
- any part of the load being dislodged or falling out of the vehicle.

It is against the law to drive a vehicle where the load is not secured. You can stop your load from moving by:

- Lashings secured to the vehicle chassis, including:
  - cross bearers
  - outriggers
  - tie rails and similar arrangements
- Blocking arrangements such as:
  - load racks
  - headboards
  - bulkheads
  - stakes in pockets
  - transverse beams
  - shoring bars
  - chocks, dunnage, etc
- containing the load by using a truck with solid sides and tailgate, a tanker or a shipping container
- covering loose loads such as sand or gravel with sheets or tarpaulins.

## Blocking

The most important part of the blocking is the headboard or bulkhead. It is best to put most loads right against the headboard to prevent the load acting like a battering ram if it moves forward. If other restraints fail in a sudden stop, the load might break the headboard. This could damage the cabin and leave you severely injured.

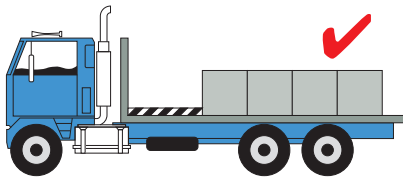

The headboard and extra blocking can be used to stop load shift.

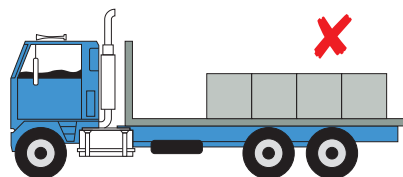

The load is not secured and could shift.

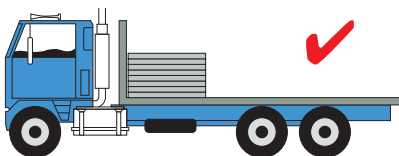

The load is correctly blocked against the headboard.

Many vehicles carry loads that could crush the driver's cab if the load shifted forward under sudden braking. If you carry loads such as coils, sheet steel, steel pipes, structural steel and timber, you should have a solidly constructed bulkhead instead of a normal headboard.

When carrying a load of metal bars, it is particularly important to ensure that all bars are secured and unable to move out of the stack. One bar that moves could go through the bulkhead.

## Stakes in pockets

These or stanchions may be used in conjunction with lashings to prevent long rigid loads such as pipes, logs etc from moving sideways.

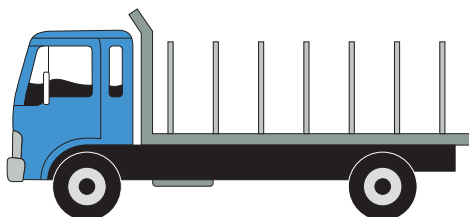

Stakes or stanchions should be used to prevent sideways movement.

## Crowned loads

It is important that long rigid loads such as pipes, logs etc be crowned to ensure the load is lashed securely without 'gaps'. Gaps in the load may allow it to move and cause the lashings to become loose.

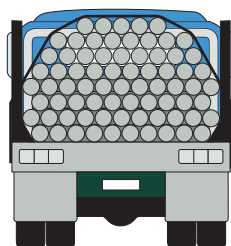

To restrain movement in loads such as pipes, they need to be crowned and have no gaps.

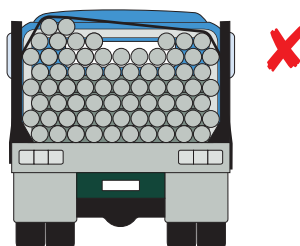

The gaps in this load can cause potentially dangerous load shift.

## Divided crowned loads

In some cases it may be necessary to divide the load into two or more stacks to crown it effectively. This can be achieved by attaching the lashings along the middle of the deck.

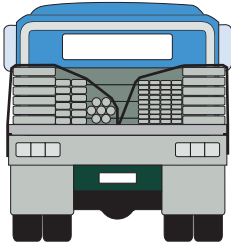

A load that is divided to minimise the chance of movement.

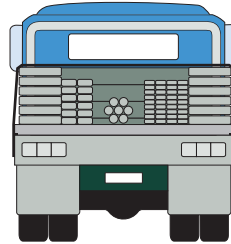

A load with substantial gaps that would allow potentially dangerous movement.

## Dunnage

This is packing placed under or between parts of the load. It is used to allow loading and unloading with forklifts or lifting slings. It is usually made of rectangular or square hardwood or softwood and must be strong enough to support the weight of the load placed upon it.

A load with multiple layers or rows must have all dunnage placed directly above the bottom dunnage. Tie-down lashings must only be placed at these positions along the load to ensure that the lashings do not loosen or overtighten if the vehicle chassis flexes.

Long rigid loads such as large diameter steel pipes must be supported in two positions to allow the vehicle to flex. Additional dunnage (and lashings) will need to be used along the lengths of more flexible loads such as plastic pipes etc.

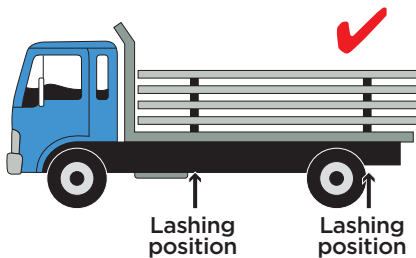

Dunnage needs to be vertically aligned to minimise movement when under lashings.

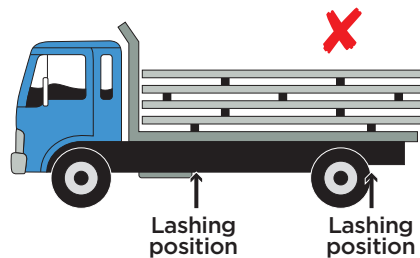

The dunnage is placed irregularly and could loosen or overtighten lashings when the vehicle is operating.

## Gates/fencing

A load can also be secured with sidegates, tailgates and other blocks. The sidegates have to be strong enough not to be forced out by the weight of the load. Other blocks should be secured and braced. You should close and lock the tailgate of your vehicle unless the load is too long. Never carry any separate part of the load on the tailgate.

Where small pipes or logs are carried, suitable sidegates or other containment methods should be used to prevent sideways movement.

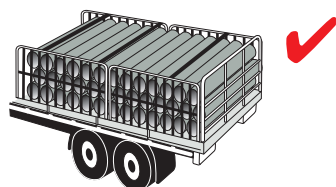

A load secured from sideways movement by gates and fencing.

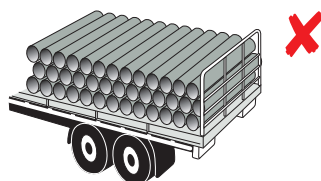

A load not secured from sideways movement.

## Containers

Vehicles used to carry containers must be equipped with special devices known as 'twist locks'. Containers have special corner-pieces which fit into the twist-locks on the vehicle. They can then be locked into place. Sometimes frames with twist-locks can be attached to the vehicle. These frames need to be securely bolted to the chassis.

A container is not properly secured unless the twist-locks are used. This applies whether the container is full or empty. A vehicle without twistlocks should not be used to carry containers. Decommissioned containers (those not carrying a load) can be chained to a vehicle for transport.

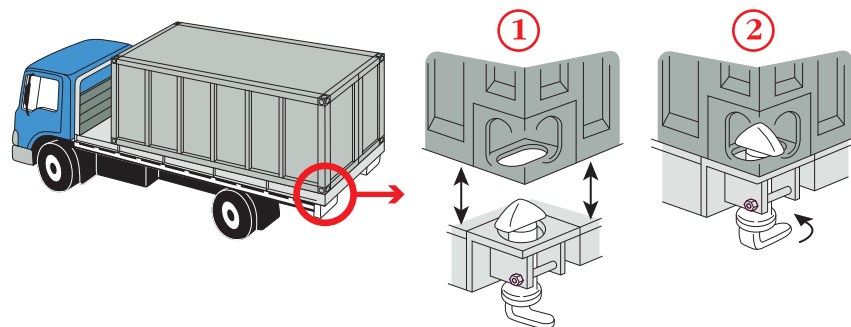

A twist lock used to secure a container.



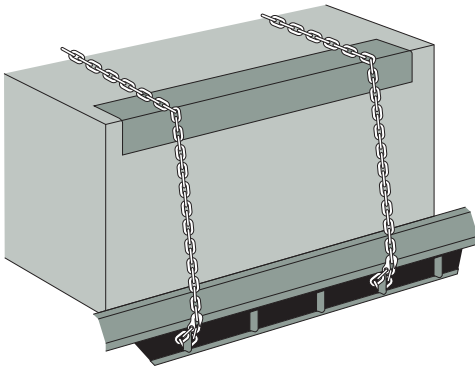

A correctly lashed and fastened load.

## Lashings

These and other fastening devices such as dogchains, cables, clamps, load binders must be in good condition. A chain is not good enough if even one link is deeply gouged, pitted or worn. Make sure the lashings are tight enough to stop any movement. Make sure the type of lashing you use is strong enough to fasten in place.

The lashings should be protected from any sharp edges on the load or on the vehicle. When using more than one lashing, secure them separately so if one line fails the others will hold.

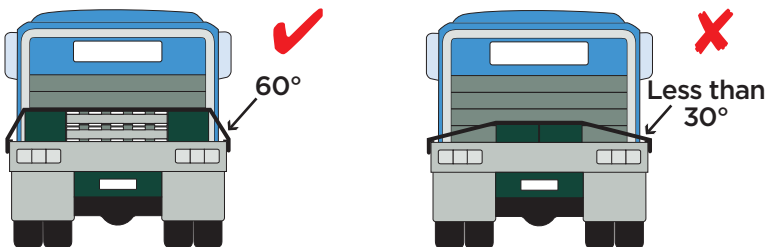

The greater the angle of the lashing to the load the greater the lashing tension will be. Angles less than 30° are not recommended.

## Belly wrapping

Belly wrapping may be used to prevent large diameter pipes or bars from rolling. When belly wrapping, the lashings must be looped over the top of the load to provide tie-down. Lashings that are looped underneath a rounded load will not prevent the load from rolling.

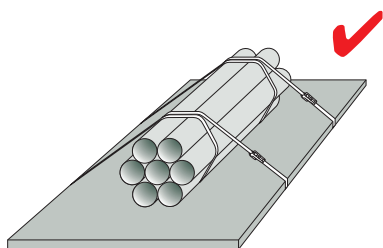

The lashings must be looped over the top to prevent rolling.

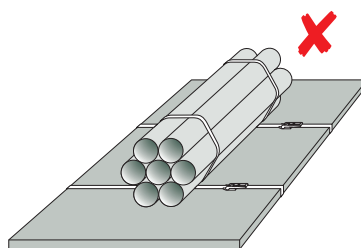

The load could roll dangerously.

## Large pipe loads

When placed across the vehicle, all upper layer pipes in the load should be individually tied down so that all pipes in the load are positively clamped to prevent sideways movement.

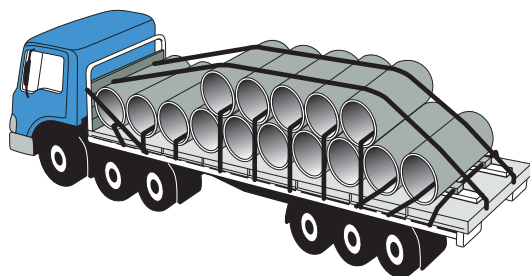

All pipes need to be clamped to prevent sideways movement.

## Load anchorage points

You cannot rely on traditional rope hooks or rings to hold anything other than light loads.

Vehicles should have load anchorage points fixed to the vehicle so that the main chassis frame takes the force of the load.

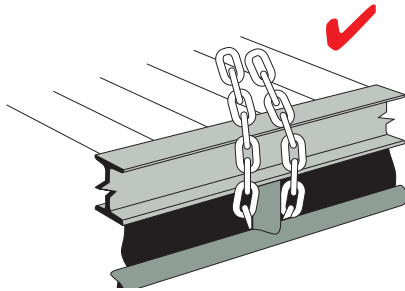

The chassis frame should be used as an anchorage point.

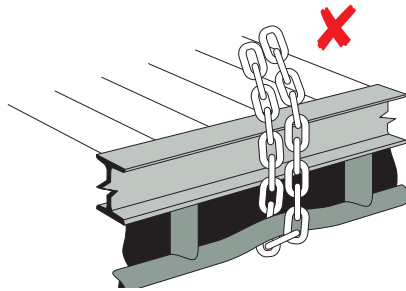

You should not rely on non anchorage points to take anything other than light loads.

## Friction

Friction cannot stop your load from moving but it can be a great help. To make the best use of friction, the base of the load and the platform should be kept clean, dry and free from grease. A slippery platform surface is always dangerous.

## Sheets and tarpaulins

Except in the case of very light bulk loads, sheets and tarpaulins are not strong enough to hold down loads, they only protect the load from the weather. Sand, gravel, etc. should always be covered.

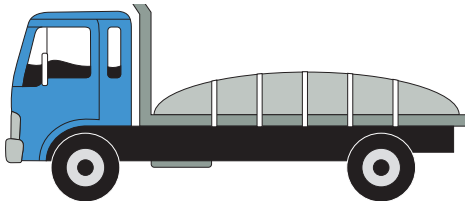

Secured sheets and tarpaulins can be used to protect loads from the weather.

## Dangerous goods

PETROLEUM FUEL	
UN No. <b>1270</b>	
HAZ CHEM <b>3YE</b>	
IN EMERGENCY DIAL <b>000 POLICE or FIRE BRIGADE</b>	
	SERVICE ADVISE <b>XYZ PETROLEUM LTD PHONE: 1111222</b>

An example of a petroleum fuel compliance plate.

Information on the transport of dangerous or explosive goods can be found in The Australian Code for the Transport of Dangerous Goods by Road and Rail available from the National Transport Commission at [ntc.gov.au](http://ntc.gov.au)

### In the event of a crash you must:

- call the police or fire brigade on triple zero **000**
- not touch spilled chemicals and avoid breathing fumes and dust
- wash off any chemicals with plenty of water if you are splashed
- keep people away from the crash site
- show the shipping documents and emergency procedure guide to the police or fire brigade when they arrive.

### The correct licence

Any driver of a vehicle which carries bulk dangerous goods must be licensed for that purpose. To find out if your vehicle is defined as carrying bulk dangerous goods, contact the NSW Environment Protection Authority (EPA).

Dangerous goods vehicle drivers are subject to the Australian Code for the Transport of Dangerous Goods by Road and Rail administered in NSW by the EPA and SafeWork NSW.

The driver must:

- be at least 21 years old
- have held a driver licence for the class of vehicle, which is to carry the dangerous goods
- have successfully completed an approved training course
- submit a medical certificate
- have a satisfactory driving history.

See Dangerous goods information at [epa.nsw.gov.au](http://epa.nsw.gov.au) or call NSW EPA on **13 15 55**.

Dangerous goods vehicle drivers are prohibited from travelling in road tunnels, unless permitted by the Commissioner of Police.

## Risks

---

Many vehicles carry dangerous loads including substances which are flammable, toxic, infectious, radioactive or corrosive.

A crash, leakage or fire involving a vehicle carrying dangerous goods could cause extensive damage, death or serious injury to many people.

Vehicles carrying flammable loads must be fitted with a switch that isolates the battery and so reduces the risk of fire. For further details contact the EPA.

In the event of a leakage accident or crash follow the process outlined on your emergency procedure guide. The procedure varies for different materials so make sure you carry the right card.

The EPA can provide you with professional advice for technical and scientific information, call **13 15 55**.



## Checklist for dangerous goods:

### 1. Consignment papers

Make sure you have these (shipping documents) that show what you are carrying.

### 2. Proper labelling

Make sure your vehicle is properly labelled.  
For bulk dangerous goods it should have:

- A hazard warning diamond at the front and rear.
- Information as required by the EPA which should be shown on three emergency information panels, one at the rear of the vehicle and one on each side, and should include:
  - the name of the substance
  - United Nations (UN) identification number
  - emergency action code
  - emergency telephone number
  - name and telephone number of the responsible company that can be contacted.

### 3. Vehicle monitoring device

If your vehicle is more than 13.9 tonnes GVM or GCM and is used for carrying bulk dangerous goods, it must be fitted with a vehicle monitoring device (such as an approved tachograph) which complies with Transport for NSW Vehicle Engineering Specification 531.

**4. Carry appropriate guides**

You must keep the Emergency Procedures Guide, a 'product' card which gives a guide to the emergency procedures that apply to the particular hazardous substance which you are carrying, together with the Vehicle Fire Card, on or near the inside of either cabin door. You are permitted to carry the Initial Emergency Response Guide instead of carrying both the product card and vehicle fire card as the guide provides similar information to the cards. The guide book and cards are published by Standards Australia.

 **5. Tank inspections**

Inspect the tank or other containers before and after loading and frequently throughout the journey.

 **6. Hatch inspections**

Inspect the hatches of the tanker and make sure the seals are in good condition. Make sure that all filling points are closed. If they are not, the tank could leak a lot in a rollover. The vapour from an open filling point could impair your driving.

 **7. Protective clothing**

Carry sufficient protective clothing so that you will be able to attend to any small leaks. You may be able to stop them before they become serious problems.

## Heavy vehicle road access permits and notices

Restricted Access Vehicles (RAVs) are vehicles, laden or unladen, exceeding the general access dimensions defined in the Heavy Vehicle (Mass, Dimension and Loading) National Regulation.

If an RAV exceeds the dimensions for general access it may be eligible to operate under a notice applicable to that vehicle. Notices provide for greater dimension/mass limits with additional considerations and route restrictions.

RAVs with dimensions or mass over the limits stated in the relevant Notice may be eligible for a NSW roads specific permit.

The National Heavy Vehicle Regulator publishes RAV road access Notices at **[nhvr.gov.au](http://nhvr.gov.au)**

For information about heavy vehicle access contact the National Heavy Vehicle Regulator on 1300 MYNHVR (**1300 696 478**) or email **[info@nhvr.gov.au](mailto:info@nhvr.gov.au)**



# Penalties

Under NSW laws, you can be penalised for traffic offences which cause inconvenience, costs, injury or suffering to others.

## Traffic offences

Penalties for breaking the traffic laws include fines, disqualification from holding or applying for a licence, licence cancellation, refusal or suspension. For a very serious offence like drink driving, you may be fined, disqualified from driving or even go to prison.

## Demerit points

---

For certain traffic offences you will have demerit points recorded against your licence. There is a limit to the number of points you can build up before your licence is suspended. Some driving offences such as speeding and not wearing a seatbelt attract double demerit points during public holiday periods.

Your licence will be suspended when you reach these limits:

- **unrestricted licence** – gold or magenta (national heavy vehicle driver licence) – 13 points in any three-year period (or 14 in the case of a professional driver).
- **provisional P2 licence** – seven points and P2 drivers receiving a suspension for unsafe driving behaviour must stay on their licence for an extra six months for every suspension they receive.
- **unrestricted licence with good behaviour period** – two points during the good behaviour period.

Your licence will be suspended when you reach or exceed the demerit points limit. A Notice of Suspension is sent to licence holders who reach or accumulate more than the number of points detailed above.

The suspension period depends on the number of points accumulated and/or type of licence held.

## Good behaviour period

---

Unrestricted licence holders can apply for a 12-month good behaviour period instead of serving the suspension. This option is not available to those already serving a good behaviour period.

Drivers who accumulate two or more demerit points while serving a good behaviour period will be suspended for double the original suspension time.

Unrestricted licence holders can apply for a good behaviour period in person at a service centre or online. A good behaviour period can be elected before the start date of the suspension. Online applications must be completed at least 2 business days before the start date of the suspension.

## Speeding offences

---

Automatic licence suspension or disqualification periods apply to drivers who commit a serious speeding offence:

- Driving more than 45km/h above the speed limit - suspension or disqualification for six months. Police can suspend and confiscate a licence at the roadside.
- Driving more than 30km/h but not more than 45km/h above the speed limit - suspension or disqualification for three months.
- These offences also carry demerit points which may contribute to another suspension period, either immediately following the speeding suspension or at another time, if drivers reach or exceed the demerit points limit.

## Speed limiter offences

---

Specified heavy vehicles are required to be fitted with a speed limiter that limits the vehicle to a maximum speed of 100km/h. A heavy vehicle fitted with a correctly operating speed limiter is 'speed limiter compliant'. A heavy vehicle operator commits a speed limiter offence if a vehicle that is required to be fitted with a speed limiter is not speed limiter compliant.

Heavy fines apply to vehicle operators, individuals or corporations for non-complying speed limiters.

## Refusal of a licence

---

Transport for NSW may refuse to renew the licence of drivers who have exceeded their demerit points limit or have committed a serious speeding offence. The periods of refusal for a licence are the same as those for suspensions.

## Safe-T-Cam

---

The Safe-T-Cam is an automated monitoring system designed to reduce the incidence of heavy vehicle speeding and driver fatigue. It can determine if a heavy vehicle has travelled at excessive average speed, or has travelled beyond prescribed driving hours, between two or more of the 24 Safe-T-Cam sites located throughout NSW.

Safe-T-Cam forms part of a coordinated heavy vehicle enforcement program that consists of Transport for NSW inspectors, heavy vehicle checking stations, periodic vehicle inspections and police enforcement.

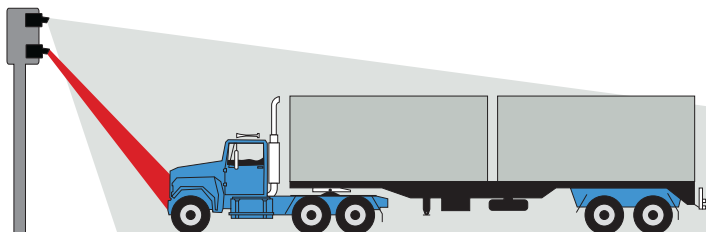

Safe-T-Cam monitors speed and driver fatigue of heavy vehicle drivers.

## Heavy vehicle safety stations

---

Heavy vehicle safety stations are permanent inspection facilities located along major transport routes. Vehicles with a GVM of more than 8 tonnes may be stopped and inspected to check they are safe and meet roadworthiness standards. Drivers are also checked to ensure they are complying with road transport laws.

## Truckalyser

---

A truckalyser is a mobile inspection device to check heavy vehicles are in a safe condition. The truckalyser tests:

- brakes by measuring the brake force generated at each tyre and calculating the brake balance on each axle
- steering and suspension to determine any serious and potentially dangerous wear in any of the components.

## Alcohol and drug offences

---

It is against the law to drive while under the influence of alcohol and drugs, including some prescribed medicines.

If you are found to be driving under the influence of drugs, for a first offence you may be fined, go to prison and be automatically disqualified from driving. Heavier penalties apply for second or subsequent offences.

It is also against the law to drive with a presence of an illicit drug. These drugs include THC (the active component of cannabis), methylamphetamine, cocaine and ecstasy. These offences are typically detected through roadside, mobile drug testing. For a first offence, you can be fined and have your licence suspended or be disqualified from driving. Heavier penalties apply for second and subsequent offences.

## Noise pollution

---

Noise can affect your physical health, cause nervous stress and annoy others. It adds to fatigue, lowers productivity and can also increase the risk of heart disease.

There are heavy penalties under environmental protection legislation for breaking the noise control law. These penalties increase significantly for repeat offences

## Types of noise pollution

1. In heavy traffic flow each vehicle contributes to the general roar. Trucks contribute about half the noise energy from traffic – even though they are less than 10 per cent of vehicles on the road.
2. There is also noise pollution from excessively noisy individual vehicles – these contribute more than their fair share to general traffic noise.

## Noisy vehicles

Excessive noise can come from:

- deterioration of the exhaust system from corrosion
- fitting an unsuitable muffler or removing sound absorbent materials
- engine modifications such as raising the maximum governed speed
- bad driving habits such as using the exhaust brake or a noisy retarder in built up areas
- body noise on hitting bumps in the road.

### Noise limits for trucks and buses in NSW

Type of engine	GVM tonnes	Height above ground of end of exhaust pipe (mm)
Spark ignition engine	More than 3.5	Less than 1500
		1500 or more
Diesel engine (horizontal exhaust)	More than 3.5 but not more than 12	Less than 1500
	More than 12	Less than 1500
Diesel engine (vertical exhaust)	More than 3.5 but not more than 12	1500 or more
	More than 12	1500 or more

For vehicles with horizontal exhausts add four decibels to these limits to allow for reflection of noise from the ground and the body of the vehicle. For example, the noise limit for a diesel truck more than 3.5 tonnes but not more than 12 tonnes GVM made before 1 July 1980 is  $103+4=107$  dB(A)

## What you can do to reduce noise

Fit a good exhaust system:

- Beware of ‘cheapies’ – they can wear out faster and may not have a warranty. A noisy muffler does not mean higher performance or better fuel consumption. Tests conducted for the NSW EPA have shown that in many cases noisy systems were no better for backpressure or fuel consumption.
- Buy quality replacement mufflers. The manufacturer’s recommended part is usually the best for all-round performance as well as noise control.

Date vehicle built	Maximum noise dB(A)
Before 1/7/83	98
On or after 1/7/83	95
Before 1/7/83	94
On or after 1/7/83	91
Before 1/7/80	107
On or after 1/7/80 and before 1/7/83	104
On or after 1/7/83	101
Before 1/7/80	109
On or after 1/7/80 and before 1/7/83	106
On or after 1/7/83	103
Before 1/7/80	103
On or after 1/7/80 and before 1/7/83	100
On or after 1/7/83	97
Before 1/7/80	105
On or after 1/7/80 and before 1/7/83	102
On or after 1/7/83	99

## Get your truck or bus tested for noise

Ask the muffler fitter to check that your new muffler has a low noise level. The legal noise limits vary according to GVM, manufacture date, type of engine and whether the exhaust pipe is vertical or horizontal.

During testing, the fitting of raincaps and elbows may deflect the radiation of noise for dB(A) testing, however, the microphone can be placed at any suitable location so long as it is more than 1.0 metre from the centre of the exhaust outlet but not in the way of the gas flow.

## Smoke from engines

---

Excessive smoke from vehicles is illegal, unpleasant and at times dangerous. It can also lead to expensive engine repairs and time off the road.

Blue smoke normally indicates engine wear or damage. Black and grey smoke results from incomplete combustion and may be caused by a number of factors. These examples can usually be fixed during routine maintenance:

- blocked air filter
- obstruction of fuel filters or water traps with dirt, grit or fuel wax
- incorrect fuel pump timing
- engine speed too high
- incorrect valve or tappet adjustment
- poor cylinder compression indicating leakage past valves or piston rings
- excessive back-pressure in exhaust system
- injectors misfiring or leaking
- faulty turbo chargers where fitted
- poor driving techniques.



## Defect notices

Defect notices are issued by authorised officers from Transport for NSW, NSW EPA, NSW Police Force and certain council employees (for minor items). There are two defect categories – minor and major (includes major grounded).

Transport for NSW can also issue formal warnings.

### Formal warning

---

#### Type of vehicle defect

These are faults that are non-safety related and are relatively simple to repair.

#### How it affects you

You may continue to use the vehicle but any necessary repairs or adjustments must be made by the time specified on the notice. Formal warnings may be issued as a Load Restraint Advice, Undue Noise Advice or a Vehicle Unroadworthiness Caution.

Empty tipper trucks can be very noisy, so drive slowly over rough roads or get rubber lining fitted to the body.

You may be penalised if your vehicle blows smoke for more than 10 seconds while under load.

### Minor defect

---

#### Type of vehicle defect

This includes faults in a vehicle's safety related systems that are not likely to cause the vehicle to become unsafe during the time specified on the notice. The vehicle may continue to be used until the expiry of time specified.

## How it affects you

Your vehicle may continue to be used up until the time specified on the notice of repair. These categories of vehicle defects are of a more technical nature and require inspection and clearance of the vehicle defect notice by either an authorised AIS examiner at an authorised inspection station or an authorised officer of Transport for NSW.

## Major defect

---

### Type of vehicle defect

'Major' category vehicle defects are serious defects in a vehicle's safety related systems that would constitute an imminent and serious safety risk if the vehicle is operated beyond the time allowed for use - generally this is not more than 24 hours. A yellow coloured defective vehicle label may be attached to the vehicle and a traffic infringement notice issued.

## How it affects you

Once repairs are completed the vehicle is to be inspected by an authorised officer of Transport for NSW or an authorised AIS examiner at an authorised inspection station for the vehicle defect notice to be cleared.

It is against the law to drive or stand a vehicle with an uncleared defect notice on a public street or use a vehicle contrary to any conditions endorsed on the defect notice.

## Major defect - grounded

---

### Type of vehicle defect

Vehicles with dangerous category defects must not be driven from the point of inspection unless the dangerous faults are repaired immediately or the vehicle is towed or carried to a place of repair.

## How it affects you

A red coloured defective vehicle label is attached to the vehicle. The issuing officer will explain the clearance procedures and where the vehicle may be inspected. In most cases the clearance procedures are the same as for major defects.

Where the vehicle defective notice is issued during the vehicle's annual HVIS inspection the yellow copy of the vehicle notice must be kept by the operator/owner and produced for renewal of the vehicle's registration.

A vehicle's registration may be suspended, if the 'cleared' blue copy is not returned within 21 days by the end of the period specified on the vehicle defect notice. Return the blue copy defect notice to a service centre or Transport for NSW.

Owners of vehicles that are issued defect notices should keep the 'cleared' yellow copy of the vehicle defect notice as a record that the vehicle defect notice was cleared.

Vehicle defect notices issued to a NSW registered vehicles by interstate authorities will involve the same follow up procedures if the notice is not cleared.

## Transport for NSW inspectors

---

The job of Inspector Vehicle Regulation (IVR) is to ensure the safety of drivers and vehicles using NSW roads. The inspectors enforce regulations for heavy vehicles, with special emphasis on:

- vehicle roadworthiness
- driving hours
- weight limit compliance
- dimension limit compliance
- noise and exhaust emissions
- registration and licensing matters.

They also check the performance and standard of Authorised Inspection Stations (HVAIS and AUVIS) and examiners.

Transport for NSW inspectors are easily recognised by their uniform and all inspectors carry identification cards that are produced on request or when entering private property.

## Compliance and Enforcement

Each of the parties in the road transport supply chain must take all reasonable steps to ensure that the driver does not breach the road transport legislation. This is the chain of responsibility (CoR) under the Heavy Vehicle National Law (NSW). CoR recognises that the actions, inactions and demands of off-road parties can influence the behaviour of a heavy vehicle driver on the road.

### How compliance and enforcement legislation affects you

Job title	Role
Consignor/dispatcher	Dispatches goods for delivery
Consignee/receiver	Orders and/or accepts the goods being delivered
Loader	Loads goods into the vehicle
Packer	Packs goods to be loaded into the vehicle
Heavy vehicle driver	Transports the load to its destination
Operator/manager	Operates and/or manages the business dispatching the goods

All parties in the supply chain – consignor/dispatcher, packer, loader, consignee/receiver, manager, as well as the driver and operator – must take positive steps to prevent a breach of the road transport mass, dimension and loading and driving hours laws. The table below sets out these responsibilities.

Under the Law, you must:

Ensure your delivery request doesn't require a truck driver to:

- transport goods that go beyond vehicle dimension or mass limits
- inappropriately secure the load
- exceed the permitted number of driving hours
- fail to have minimum rest periods
- exceed the speed limits.

Assume the same responsibilities as the consignor/dispatcher, plus a truck driver:

- must not knowingly encourage or reward a breach of the mass, dimension, load restraint or driving hours laws.

Ensure the vehicle's load:

- doesn't exceed the dimension or mass limits
- cannot become unstable, move or fall off the vehicle.

Ensure that when goods are packed:

- documentation of the load is accurate, not false or misleading
- any goods packed in freight containers don't exceed the container's gross weight or safety approval rating.

Maintain current obligations to ensure:

- the vehicle does not exceed dimension or mass limits
- the load is appropriately restrained
- all required equipment is properly fitted to the vehicle
- required rest breaks are taken and driving hours regulations and speed limits are observed
- safe and responsible driving behaviour is demonstrated at all times.

Be responsible for ensuring:

- rosters do not require truck drivers to exceed the permitted number of driving hours
- accurate records are kept of drivers' activities, including driving, work and rest times
- vehicle speed limiters are functioning
- loads do not exceed dimension or mass limits and are properly restrained using appropriate restraint equipment.

# Industry glossary

**ABS** – An abbreviation for anti-lock braking systems.

**ADR** – Australian Design Rule. A set of regulations governing vehicle design.

**Aggregate mass** – Maximum allowable loaded mass of a particular vehicle or combination comprising the GVM or GCM plus the overload tolerance applicable in a given state.

**Aggregated trailer mass** – The total mass of a trailer carrying the maximum load as specified by the trailer manufacturer. It includes the mass of the drawbar as well as the mass on the axles.

**Air suspension** – A suspension system in which the weight of the vehicle is supported by air bags containing compressed air and the axles are held in position longitudinally and laterally by bushed rods.

**Air trip** – An air-activated release catch on a tipper tailgate that is operated from the cabin.

**Articulated vehicle** – A vehicle with flexibly connected sections. Usually applied to a prime mover and semi-trailer as opposed to a truck and trailer and known as a combination vehicle.

**Anchor point** – Fitting or attachment on a vehicle or load to secure lashings.

**Automatic tow coupling** – The most common type of heavy trailer hitch in Australia and Europe.

**Auxiliary gearbox** – A secondary gearbox that may be located before or after the main gearbox to provide additional overdrive or reduction ratios.

**Axle group** – A group of axles (or a single axle) supporting one section of a vehicle.

**A-Train** – Usually refers to a prime mover and semi-trailer towing a trailer.

**Baffles** – Barriers fitted crosswise and lengthwise inside tanks to limit surging of fluids (or loads which behave like fluids) during acceleration, braking and cornering.

**Baulking** – A solid object, often a large piece of timber, placed against the load and fixed securely to the vehicle to prevent movement of the load.

**B-Double** – An articulated vehicle with a second semi-trailer attached to the rear of the first semi-trailer by means of a turntable.

**Blocking** – Material, usually timber, placed between the load and the vehicle structure, to prevent movement of the load.

**Bolster** – A piece of steel or heavy timber firmly attached to the vehicle (often bolted to the chassis) to support the load and/or prevent it from moving.

**Bulker** – A container fitted with loading hatches on the roof and discharge hatches on the doors and front wall.

**Bulkhead** – A term sometimes applied to the gate at the front of the tray body or flat top trailer which is built heavier than side gates.

**Cab chassis** – A truck with only the cab fitted.

**Chassis** – A vehicle frame.

**Chocks** – Wedge shaped blocks used to prevent movement of the load.

**Clutch brake** – A device actuated by the last inch of clutch pedal travel which brakes the spinning gears in the transmission.

**Coaming** – A frame border around the outside of a vehicle's loading deck.

**Combination vehicle** – A rigid truck (or bus) towing one or more trailers.

**Constant mesh transmission** – A transmission in which all gears remain in mesh at all times.

**Contained load** – A load prevented from dislodging from the vehicle by the vehicle structure, gates, sides, racks, headboards, stanchions or other parts of the load.

**Container** – A box used for transporting goods in bulk. Standard lengths are 20 and 40 feet.

**Converter dolly** – A unit designed to convert a semi-trailer to a dog trailer. A dolly can also be a device for spreading the weight of overdimensional loads.

**Corner protectors** – Material used to protect lashings and the exposed edges of loads and vehicles, and to allow lashings to slide freely when being tensioned.

**Cradle** – A frame shaped to support a rounded object.

**Crashbox** – An older type transmission in which the ratios were changed by sliding the various gears into and out of mesh with each other.

**Cribbing** – A method of supporting a load on a stable column of packing of uniform thickness, stacked in pairs, with alternate layers at 90 degrees to one another.

**Cross-member** – A support placed crosswise below the loading deck.

**Deck** – The load carrying platform.

**Dog** – A chain tensioner incorporating an over-centre locking action with a fixed or pivoting lever.

**Dog trailer** – A trailer with two axle groups, the front group being steered by the drawbar coupled to a towing vehicle.

**Double trailer combination** –

Combination of a prime mover, semi-trailer and trailer.

**Drawbar length** – The distance from the line of the towing pivot to the centreline of the leading axle group of the trailer.

**Drawbar stand** – A leg that holds a trailer drawbar at coupling height to allow for easier hook-up.

**Drive shaft** – See ‘Tail shaft’.

**Driveline** – The motor, clutch, gearbox, drive shafts, diff(s) and axle(s).

**Drivetrain** – As for Driveline but usually does not include the engine.

**Dry freight container** – A normal, fully enclosed container with doors at the back and occasionally on one side.

**Dual wheels** – A matched pair of wheels attached to each end of an axle.

**Dunnage** – Packing material (eg pieces of timber, mats) placed between the cargo and truck platform, or between items of cargo, to level the load and/or increase friction so the load is less likely to move during the journey. It is also used to leave a gap between a load and the load deck, or different parts of the load, so forklift tyres can be placed under for lifting.

**Flat rack** – A steel base for supporting loads fitted with receptacles for twist locks and provision for forklift operation.

**Flat top** – A truck, trailer or semi-trailer that has flat goods carrying area without sides.

**Flush deck** – A flat loading deck without a raised coaming.

**Forward control vehicle** – A truck with the cab mounted over the engine.

**Gates** – Permanent or removable vertical frames used at the front, side and rear of a vehicle’s loading deck to contain its load. The front gate is usually called a loading rack or load rack.

**Gross combination mass (GCM)** – The loaded weight of an articulated vehicle or combination vehicle.

**Gross road train mass (GRTM)** – The loaded weight of a road train.

**Gross trailer mass (GTM)** – The mass on the axle(s) of a trailer when fully loaded.

**Gross vehicle mass (GVM)** – The loaded weight of a rigid vehicle.

**Inter-axle differential** – A differential that operates between two driven axles to allow one axle to turn at a slightly different speed to the other.

**Inter-axle lock** – Locks the inter-axle differential so drive is shared equally by both driven axles to reduce wheel spin and increase traction in slippery conditions.

**Lashings** – Fastening devices, chains, cables, ropes or webbing used to restrain loads.



- Lashing capacity (LC)** – The maximum force (in kilograms) that a lashing system is designed to sustain in use.
- Load Binder** – A device used for tensioning a lashing.
- Load capacity** – The difference between the GVM or GTM of a vehicle and its tare mass.
- Load limit** – The maximum load that may be carried in, or on any motor vehicle upon the road.
- Load mat** – A sheet of material used to increase friction and protect the load.
- Pallet** – A portable platform or tray onto which loads are placed for mechanical handling.
- Pantehnicon** – A vehicle with a body enclosed by solid rigid sides and roof.
- Pawl** – A lever or lock which protects reverse rotation on a winch.
- Pockets** – Housings or sots fixed to the vehicle to locate gates, stakes or loading pegs.
- Prime mover** – A short wheel base truck used to tow a semi-trailer.
- Professional Driver** – A professional driver is a motor vehicle driver whose primary work is to transport goods or is a driver of a bus, taxi or hire car, accredited under the Passenger Transport Act 1990. Drivers will not qualify if driving a motor vehicle is incidental to their primary work (eg a salesperson, carer, tow truck operator or food vendor etc).
- Rear marker or reflector plates** – Red and yellow plates which must be fitted to the rear of heavy vehicles to make them more visible when they are slow moving or parked.
- Road train** – Either a truck hauling two or more trailers, or a prime mover and semi-trailer hauling one or more trailers (Note: this is not a B-double, which consists of a prime mover and two semi-trailers).
- Rope hooks** – Attachments fixed to the surrounds of the loading deck for securing of tarpaulin and tie-down ropes.
- Semi-trailer** – A semi-trailer has one axle group at the rear and is designed so that the front is supported by the prime mover that tows it.
- Speed limiter** – A engine management device that limits the top speed of a truck without limiting engine revs or power in the lower gears.
- Shackle** – A metal coupling link closed by a bolt which can be used for attaching chain fittings.
- Shoring bar** – Adjustable metal beam used to restrain or segregate sections of load.
- Sling** – A length of hemp-core rope, webbing or steel-wire rope with eyes formed at each end.
- Spreader** – A transverse spar or frame used to support tarpaulins and side gates.

**Stanchion** – A large upright fixed to the side of a vehicle for sideways restraint.

**Stillage** – A metal structure for containing individual items of load.

**Strut** – A rigid member which can support loads in the direction of its length.

**Synchromesh transmission** – A transmission in which the speeds of the gears are matched or 'synchronised' by means of in-built synchronising clutches before they are meshed.

**Tachograph** – A trip recorder incorporating a clock, speedometer and often a rev counter that inscribes a record of a journey on circular paper graph.

**Tachometer** – An instrument for measuring engine revolutions.

**Tare mass** – The mass of a vehicle without its load.

**Tarpaulin (tarp)** – A waterproof sheet used to cover and protect goods from the weather.

**Tie rail** – A round rail which skirts the perimeter of the loading deck below the coaming rail.

**Torque** – The turning force or turning effort of a shaft. Engine torque is the turning force available at the crankshaft.

**Trailer** – A non-powered vehicle built to tow behind a motor vehicle.

**Trailer coupling** – The device that attaches a trailer to a towing vehicle.

**Truck winch** – A device used for tensioning a lashing which is normally placed under the coaming rail and may be fixed in position using the tie-rail or slide on a rack.

**Twist lock** – A locking device with a rotating head which normally engages a corner casting on the load.

**Unladen mass** – The mass of a motor vehicle without a load, but including all tools, fixed cranes, oil and fuel in the tanks. The unladen mass of an articulated vehicle is the unladen mass of the prime mover only.

**Work diary** – Driver's record of hours driven and rest periods taken.

**Winch** – A device for tensioning lashings via a rotating spool.

# Index

## A

---

Alcohol 25, 37, 38, 44, 114  
Assessing fitness to drive 10  
Articulated vehicle 11, 15, 60, 65, 71, 95, 124

## B

---

B-Double 11, 16, 59, 85, 124, 127  
map 25, 60, 132  
permits 60, 110  
routes 25, 60, 88  
Belly Wrapping 104  
Blocking 99, 124  
Brakes 48, 49, 50, 51, 52, 68, 69, 70, 71, 80, 115, 126  
Bus 11, 20, 21, 26, 27, 39, 54, 56, 61, 62, 63, 89, 122, 132  
B signals 63  
driving hours 29, 30, 65, 67, 113, 121, 123  
priority for 63  
turning 57

## C

---

Chain of responsibility 27, 55, 122  
Compliance and enforcement legislation 122  
Containers 102, 109, 123, 125  
Contained loads 90, 125  
Coupling 21, 73, 80, 82, 84, 85, 87, 128  
Crash avoidance space 43, 44, 45  
Crash - in the event of 106, 107  
Crossing or entering traffic 56  
Crowned loads 100, 101

## D

---

Dangerous goods 106, 107, 108, 132  
Dangerous projections 95  
Defect notices 119, 120, 121  
Depressants 40  
Distances between large vehicles 45  
Dog Trailer 125  
Double-declutching 75  
Driver fatigue 23, 24, 25, 26, 113  
Driving hours regulation 29, 121, 123  
Drugs 37, 38, 39, 40, 44, 114  
Dunnage 99, 101, 126

## E

---

Electrical system 73

## F

---

Fatigue 22, 23, 24, 25, 26, 27, 28, 29, 30, 31, 32, 33, 34, 35, 39, 44, 55, 113, 114  
Fire 64, 107  
Flammable load 107  
Flashing lights 75, 76  
Friction 105

## G

---

Gates/fencing 102, 126  
GCM 65, 77, 93, 126  
Gear box 20, 74, 75  
Gears 51, 52, 75  
GTM 76, 126  
GVM 93, 94, 126

## H

---

Health 22, 23, 25, 39, 114  
Heavy trailer 95  
High loads 91  
HVIS 121, 132

## I

---

Inspections 67, 68, 79, 109, 113  
Intersections 56, 57

## J

---

Jack knife 47, 72

## L

---

Laden mass 77  
Lashing 100, 101, 103, 104, 127  
Learning to drive 18  
Level crossing 48  
Licence classes 11  
LR – Light Rigid 12  
MR – Medium Rigid 13  
HR – Heavy Rigid 14  
HC – Heavy Combination 15  
MC – Multi Combination 16  
Dangerous goods 106  
Tests 19  
Light traffic roads 61  
Load anchorage points 105  
Load capacity 127  
Load restraints 98  
Log book 18, 19  
Long vehicles 45, 61  
LPG and CNG 73, 74

## M

---

Mass limit 20, 88, 93, 110, 123  
Medical assessment 10  
Medication 41  
Monitors 65, 66  
Moving off 46, 69, 85

## N

---

Noise pollution 114, 115

## O

---

Overloading 93, 97  
Overtaking 45, 58

## P

---

Pre-departure checks 21, 68, 79  
Professional Driver 22, 127  
Projected loads 94, 95

## R

---

Rear marking plates 76, 77  
Reversing 21, 58  
Rigid vehicle 11, 12, 13, 14, 95, 97  
Road train 45, 54, 59, 126, 127  
map 59  
permit 60  
routes 59, 60  
Roadside rest areas 25, 132  
Roadworthiness 68, 79, 113  
air brakes 50, 68, 70, 71, 80  
body/condition 68  
electrical system 73  
exhaust system 73  
fuel system 73, 74

lights and indicators 75, 76  
 noise pollution 114, 115  
 rear marking plate 76, 77  
 rust 77  
 seats and seatbelts 78  
 smoke from engines 118  
 steering 78  
 structure 78  
 suspension 78  
 truckalyser 114  
 vacuum 69  
 warning lights 75, 76  
 wheels and tyres 78  
 windscreens 78  
 Rollover 46, 91, 109  
 Ropes 10, 127

## S

---

Safe-T-Cam 113, 132  
 Seat belts 41, 78  
 Sheets and tarpaulins 90, 99, 105, 127  
 Skidding 52, 56, 72  
 Slowing and stopping 52  
 Smoke from engines 118  
 Speed compliance regulation 54  
 Speed limiters 54, 112, 127  
 Speed limits 54, 55, 65, 112  
 Speed retarders 72  
 Stakes 99, 100, 127  
 Stanchions 100, 125  
 Stimulants 38, 39

## T

---

Tankers 91  
 Tarpaulins 90, 99, 105, 127  
 Three Points of Contact 42

Tie down angles 101, 104  
 Transitional Fatigue Management Scheme (TFMS) 28  
 Trailer brake 46  
 Trailer swing 47  
 Transport for NSW Inspectors 67, 113, 121  
 Truck and bus lanes 62, 63  
 Truckalyser 114  
 Turning 57  
 Twist locks 102, 126  
 Tyres 78, 81, 93, 97

## U

---

Uncoupling 21, 82, 83, 86  
 Unladen mass 128

## V

---

Vehicle  
 dimensions and loading 88, 93  
 height 60  
 inspection 113, 120, 121  
 length 60, 95  
 monitors 65, 66  
 posture 80  
 speed limits 54, 55, 65, 112  
 width 89, 94

## W

---

Warning triangles 62, 81  
 Weight - Maximum axle loads 89  
 Work diary 18, 36, 37, 65, 128

# Useful contacts

## Dangerous goods

---

### **NSW Environment Protection Authority (EPA)**

Call **13 15 55** or online at [epa.nsw.gov.au](http://epa.nsw.gov.au)

## SafeWork NSW

---

### **SafeWork Assistance Services**

Call **13 10 50**

## Buses Driver Authority

---

To apply for a bus or coach driver licence, call **13 22 13** or apply online for a new Bus Driver Authority.

## Transport for NSW

---

### **Heavy Vehicle Customer Service**

Call **1300 364 847**

- Heavy Vehicle Inspection Station (HVIS) availability and bookings
- Heavy vehicle registrations
- Vehicle emissions management program enquiries
- Safe-T-Cam operations
- 3 strikes program.

### **Technical Enquiries**

Call **1300 137 302**

Email [technical.enquiries@transport.nsw.gov.au](mailto:technical.enquiries@transport.nsw.gov.au)

- Light and heavy vehicle technical information
- Road freight regulations
- Heavy vehicle safety standards.

### **NSW Rest areas and driver reviver sites**

Call **13 22 13** or for maps on NSW rest areas see [roads-waterways.transport.nsw.gov.au](http://roads-waterways.transport.nsw.gov.au)

## National Heavy Vehicle Regulator

---

**Oversize Overmass permits**, apply online at [nhvr.gov.au](http://nhvr.gov.au)

Call 1300 MYNHVR (**1300 696 487**)

Email [info@nhvr.gov.au](mailto:info@nhvr.gov.au)



**nsw.gov.au**

**13 22 13**

**Disclaimer**

While all care is taken in producing this work, no responsibility is taken or warranty made with respect to the accuracy of any information, data or representation. This work is not intended to substitute a reader's reference to relevant laws and Transport for NSW expressly disclaims all liability in respect of the consequences of reliance on the contents of this work.

**© Transport for New South Wales (2022)**

Users are welcome to copy, reproduce and distribute extracts from this work for non-commercial purposes only, provided Transport for NSW is acknowledged as the copyright owner and the title of this work is referenced as the source.

ISSN 1039-3633

Pub. 07.353

Catalogue number 48026532  
(04/22)